

Home / Archives / Vol. 14 No. 1 (2012): MARCH 2012

## Vol. 14 No. 1 (2012): MARCH 2012

Published: 2012-03-14

### Articles

---

A Finite Element Analysis of Bearing Resistance of Timber Loaded through a Steel Plate

Awaludin A., Hirai T., Hayashikawa T., Leijten A.J.M.

1-6

 PDF

---

Mechanical Properties of Clayey Sand Treated with Cement-Rubbershreds

Chan C.M.

7-12

 PDF

---

Use of Recycled Concrete Aggregate in Controlled Low-Strength Material (CLSM)

Naganathan S., Mustapha K.N., Omar H.

13-18

 PDF

---

Ductility of a 60-Story Shearwall Frame-Belt Truss (Virtual Outrigger) Building

Pudjisyuradi P., Lumantarna B., Tandya H., Loka I.

19-25

 PDF

---

Assessing Risk Management Capability of Public Sector Organizations Related to PPP Scheme Development for Water Supply in Indonesia

Pangeran M.H., Pribadi K.S., Wirahadikusumah R.D., Notodarmojo S.

26-35

 PDF

---

Rainwater Management Model Development for Agriculture in the Savu Island Semi-Arid Region

Susilawati C.L.

36-41

 PDF

---

Selecting Materials for Environmental-Friendly Buildings: The Need for Improved Environmental Impact Data

Nachawit T.

42-50

 PDF

---

## **Technical Notes**

---

Application of Prefabricated Vertical Drain in Soil Improvement

Tedjakusuma B.

51-56

 PDF

---

Focus and Scope

Peer Reviewers

Author Guidelines

Peer Review Process

Publication Ethics

Author Fees

Open Access

Plagiarism Check

---

**CED Indexing & Abstracting**

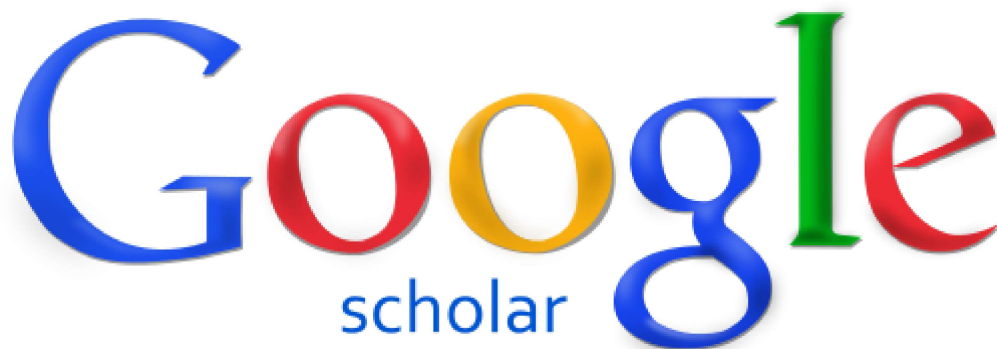



# Crossref

# DOAJ



**Editor and Administration Address:**

Institute of Research and Community Outreach  
Petra Christian University

Jl. Siwalankerto 121-131, Surabaya 60236

Indonesia

Phone: +62-31-2983139, 2983147

Fax: +62-31-8436418, 8492562

E-mail:

[dimensi-sipil@petra.ac.id](mailto:dimensi-sipil@petra.ac.id)

Homepage:

<http://ced.petra.ac.id>

---

**Accredited by the Directorate General of Higher Education, Indonesia**

**Vol 2 - Vol 4** : No. 395/DIKTI/Kep/2000

**Vol 5 - Vol 7** : No. 49/DIKTI/Kep/2003

**Vol 8 - Vol 10** : No. 55a/DIKTI/Kep/2006

**Vol 11 - Vol 13** : No. 110/DIKTI/Kep/2009

**Vol 14 - Vol 19** : No. 80/DIKTI/Kep/2012

**Vol 20** : No. 51/E/KPT/2017

---

**00272414** View My Stats

---

CED is published by The Institute of Research & Community Outreach - Petra Christian University,  
Surabaya, Indonesia

©All right reserved 2021. Civil Engineering Dimension, ISSN: 1410-9530, e-ISSN: 1979-570X

Platform &  
workflow by  
**OJS / PKP**

---

Home / Editorial Team

## Editorial Team

### Editor in Chief

**Prof. Dr. Djwantoro Hardjito**

(Petra Christian University, Surabaya, INDONESIA, SCOPUS ID = 6508089898)

### Associate (Handling) Editors

**Prof. Dr. Benjamin Lumantarna**

(Petra Christian University, Surabaya, INDONESIA, SCOPUS ID = 54179537600)

**Dr. Doddy Prayogo**

(Petra Christian University, Surabaya, INDONESIA, SCOPUS ID = 55959834900)

### Advisory International Editorial Boards

**Prof. Dr. David Arditi**

(Illinois Institute of Technology, Illinois, USA, SCOPUS ID = 35614735000)

**Prof. Dr. Stephen Olu Ogunlana**

(Heriot-Watt University, Edinburgh, UNITED KINGDOM, SCOPUS ID = 6701638480)

**Prof. Dr. Priyan Mendis**

(University of Melbourne, Melbourne, AUSTRALIA, SCOPUS ID = 7003700296)

**Prof. Dr. Hu, Hsuan Teh**

(National Cheng Kung University, Tainan, TAIWAN, SCOPUS ID = 55805441800)

**Prof. Dr. Henk Marius Jonkers**

(Delft University of Technology, Delft, NETHERLAND, SCOPUS ID = 7004676830)

**Prof. Dr. Buntara S. Gan**

(Nihon University, Tokyo, JAPAN, SCOPUS ID = 53864786800)

**Prof. Dr. Worsak Kanok-Nukulchai**

(Asian Institute of Technology, Bangkok, THAILAND, SCOPUS ID = 7004839869)

**Prof. Dr. Jeff Budiman**

(Illinois Institute of Technology, Illinois, USA, SCOPUS ID = 6603239355)

**Prof. Dr. Iswandi Imran**

(Bandung Institute of Technology, Bandung, INDONESIA, SCOPUS ID = 6603209142)

**Prof. Dr. Masyhur Irsyam**

(Bandung Institute of Technology, Bandung, INDONESIA, SCOPUS ID = 6505844516)

**A/Prof. Dr. Riza Yosia Sunindijo**

(University of New South Wales, Sydney, AUSTRALIA, SCOPUS ID = 21741351400)

**A/Prof. Dr. Benny Suryanto**

(Heriot-Watt University, Edinburg, UNITED KINGDOM, SCOPUS ID = 36618184800)

Focus and Scope

Peer Reviewers

Author Guidelines

Peer Review Process

**Publication Ethics**

Author Fees

Open Access

Plagiarism Check



**KEMENTERIAN RISET, TEKNOLOGI, DAN PENDIDIKAN TINGGI**  
DIREKTORAT JENDERAL PENGUATAN RISET DAN PENGEMBANGAN  
DIREKTORAT PENGELOLAAN KEKAYAAN INTELEKTUAL

# Sertifikat

Kutipan dari Keputusan Direktur Jenderal Penguatan Riset dan Pengembangan Kementerian Riset, Teknologi, dan Pendidikan Tinggi Republik Indonesia  
Nomor: 51/E/KPT/2017, Tanggal 4 Desember 2017  
Tentang Hasil Akreditasi Terbitan Berkala Ilmiah Elektronik  
Periode II Tahun 2017

Nama Terbitan Berkala Ilmiah  
**Civil Engineering Dimension**  
ISSN: 1979-570X  
Penerbit: Universitas Kristen Petra

Ditetapkan sebagai Terbitan Berkala Ilmiah

## **TERAKREDITASI**

Akreditasi sebagaimana tersebut di atas berlaku selama  
5 (lima) tahun sejak ditetapkan.



Jakarta, 5 Desember 2017

Direktur Pengelolaan Kekayaan Intelektual,

*[Signature]*  
Dr. Sadjuga, M.Sc  
NIP. 195901171986111001



## Ductility of a 60-Story Shearwall Frame-Belt Truss (Virtual Outrigger) Building

Pudjisuryadi, P.<sup>1</sup>, Lumantarna, B.<sup>1</sup>, Tandya, H.<sup>2</sup>, and Loka, I.<sup>2</sup>

**Abstract:** Researches have been conducted to study Shearwall-frame combined with belt truss as structural system (SFBT), in which the post-elastic behavior and ductility of this structural system are explored. A 60-story SFBT building, with a ductility set equal to 3.75 (value for fully ductile cantilever wall) is considered. The Elastic Response Spectrum used for design is taken from Zone 2 of Indonesian Seismic Map. Capacity design method according to Indonesian Concrete Code is employed. The seismic performance is analyzed using static non-linear push-over analysis and dynamic non-linear time-history analysis. Spectrum consistent ground motions of the May 18, 1940 El-Centro earthquake N-S components scaled to maximum accelerations of various return periods (50, 200, and 500 years) are used for analysis. The results of this study show that plastic hinges mainly developed in beams above the truss, columns below the truss, and bottom levels of the wall. The building shows no indication of structural instability.

**Keywords:** Ductility, shear wall frame–belt truss, static non-linear push over analysis, dynamic non-linear time history analysis.

### Introduction

Outrigger structural system has been used successfully to reduce lateral displacement of tall building. Unfortunately the installation of outriggers restricts the utilization of the floors occupied by the outriggers. Nair [1] proposed to use belt truss instead of outrigger and named the system virtual outrigger. Nair [1] showed that shear wall belt truss structure, although not as good as outrigger, could effectively reduce the lateral displacement in the elastic region. Adhi and Tenggara [2], and Lumantarna et al [3,4] considered shearwall-frame belt truss (SFBT) and showed the same behavior.

### Belt Truss as Virtual Outrigger

Belt truss is a system of trusses installed at the perimeter of Shearwall–Belt Truss structural system. Nair [1] introduced the belt truss as virtual outrigger due to the fact that it is not connected directly to the core, but still maintain the function of an outrigger. Location of belt truss in a high rise building can be seen in Figure 1.

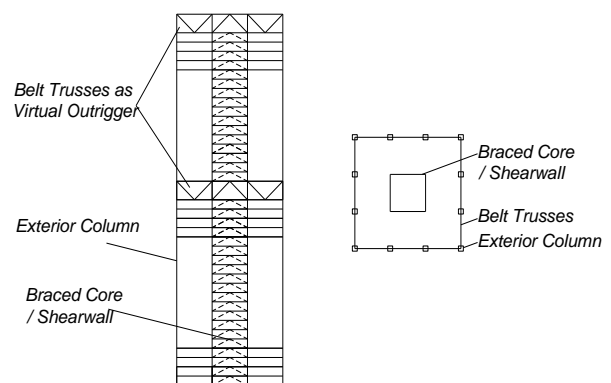

**Figure 1.** Typical Belt Truss Location in a Highrise Building [1]

In order to keep the function as outrigger, this system requires the floor diaphragm to convert the core overturning moment due to lateral load into a couple of horizontal forces (Figure 2a). Further, this horizontal forces will be converted as axial forces in exterior columns (Figure 2b).

### Post Elastic Behaviour of SFBT

Pudjisuryadi and Lumantarna [5,6] studied the post elastic behavior of a 30 story SFBT structure (Figure 3) assuming a structural ductility of 3.75 (reduction factor,  $R=6.0$ ) [7]. Ductility is defined as the ability of a structure to undergo repeated plastic deformations while keeping adequate strength and stiffness to maintain overall stability. Ductility ( $\mu$ ) of a structure is expressed as the ratio of near collapse displacement ( $\delta_m$ ) with respect to displacement at the first

<sup>1</sup>Department of Civil Engineering, Faculty of Civil Engineering and Planning, Petra Christian University, Surabaya, INDONESIA.  
Email: pamuda@petra.ac.id

<sup>2</sup>Alumnus, Department of Civil Engineering, Faculty of Civil Engineering and Planning, Petra Christian University, Surabaya, INDONESIA.

**Note:** Discussion is expected before June, 1<sup>st</sup> 2012, and will be published in the "Civil Engineering Dimension" volume 14, number 2, September 2012.

Received 26 October 2011; revised 02 January 2012; accepted 11 January 2012.

yield ( $\delta_y$ ), which in the current Indonesian Seismic Code [7], is expressed as Equation 1.

$$1.0 \leq \mu = \frac{\delta_m}{\delta_y} \leq \mu_m \quad (1)$$

In the code, both Shearwall–Belt Truss and Shearwall Frame–Belt Truss systems are not categorized. The most similar system is the Shearwall Frame system, which has ductility value ranges from 3.4 to 4.0. Failure (damage index >1.0) appeared in the short beams connecting the structural walls to adjacent columns.

In subsequent study, Prasetyo and Sumendap [8] studied similar 30 story building with some structural modification to eliminate the short beams (Figure 4). Results showed that there is no elements failure (damage index <1.0) in the building. This study intends to further explore the adequacy of value 3.75 as ductility in SFBT system by doubling the building height.

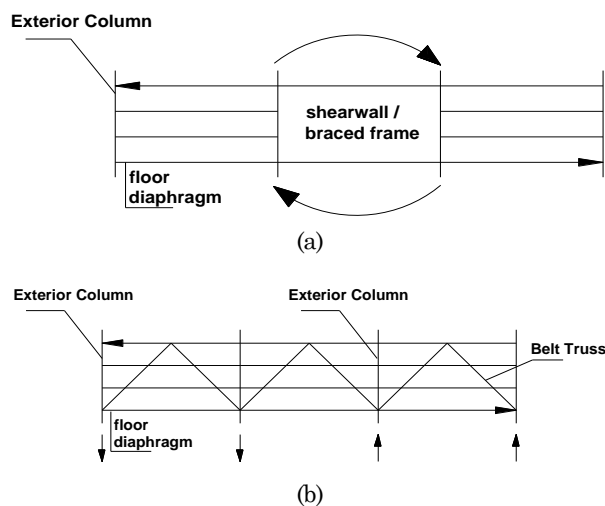

**Figure 2.** (a) Conversion of Core Overturning Moment into Coupled Horizontal Forces (b) Conversion of Coupled Horizontal Forces into Axial Forces in Exterior Columns

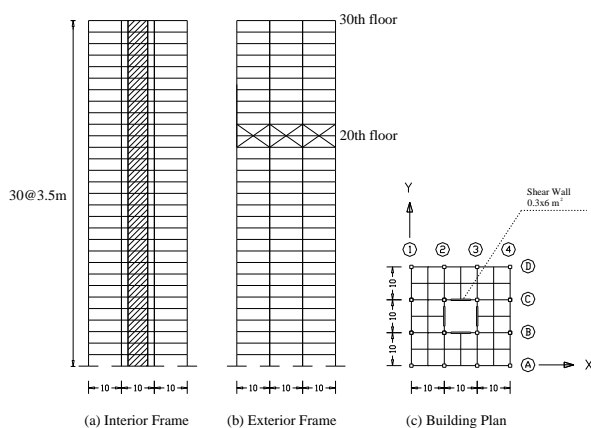

**Figure 3.** The 30-Story SFBT Building Considered by Pudjisuryadi and Lumantarna [5,6]

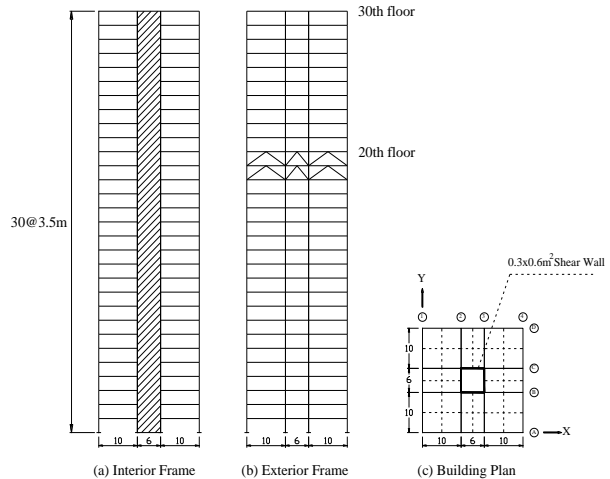
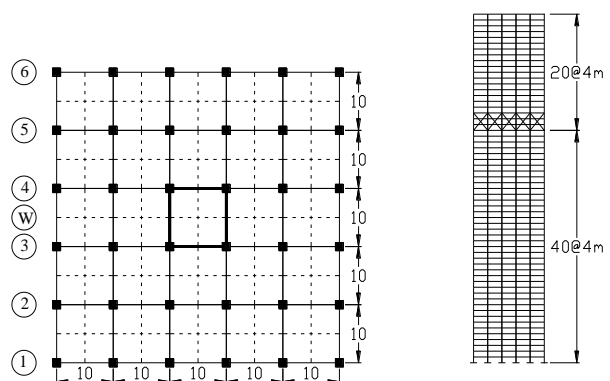

**Figure 4.** The 30-Story SFBT Building Considered by Prasetyo and Sumendap [8]

### Building and Loads Considered

In this study, a 60 story building with SFBT as lateral resisting system is evaluated. The building consists of five spans (ten meters each) in both direction, and a three story belt truss is installed at two third of building height (Figure 5). Dimensions of structural elements used can be seen in Table 1. The building is design according to the current Indonesian Seismic and Concrete Codes [7, 9]. Seismic zone 2 and soft soil condition are used for this study. Ductility value of 3.75 ( $R = 6.0$ ) is assumed in the design.

The post elastic behaviour of this building is evaluated using static non-linear push-over analysis (PO) and Dynamic non-linear Time History analysis (NLTH). The load pattern used for static non-linear push-over analysis is the building’s first mode. Spectrum consistent ground acceleration is used for dynamic non-linear time history analysis. The spectrum consistent ground acceleration is modified from the North-South Component of El Centro 18 May 1940 using RESMAT a program developed at Petra Christian University [10].

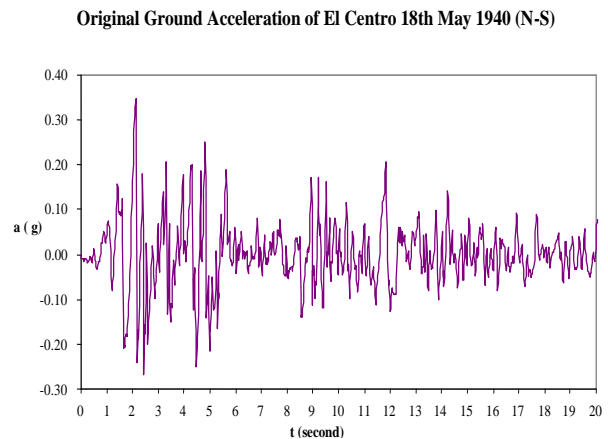

**Figure 5.** Plan and Belt Truss Location of the Building

The original ground acceleration is shown in Figure 6, while the modified ground acceleration consistent with a 500 years return period spectrum of Zone 2, soft soil, in accordance to the Indonesian Earthquake Code SNI 03-1726-2002 [7] is shown in Figure 7. Figure 8 shows comparison of respons spectra given in the code, El-Centro N-S Component, and the Modified Ground Acceleration. The modified ground acceleration (Figure 7) is then scaled down to earthquake with 50 and 200 years return period levels by using PGA factor given in [11]. The behavior of the building subjected to three levels of ground acceleration (50, 200, and 500 years return period) is analysed. Both PO and NLTH analysis are performed using SAP2000 [12].

**Table 1.** Dimension of Structural Elements

Element	Remark
• Beams; $f_c' = 30$ MPa; $f_y = 400$ MPa	0,30 x 0,90 m <sup>2</sup> , and 0,50 x 1,00 m <sup>2</sup>
• Belt Trusses; $f_c' = 50$ MPa; $f_y = 400$ MPa	1,00 x 2,50 m <sup>2</sup>
• Columns (Story 1 – Story 20); $f_c' = 50$ MPa; $f_y = 400$ MPa	1,40 x 1,40 m <sup>2</sup>
• Columns (Story 21 – Story 40); $f_c' = 40$ MPa; $f_y = 400$ MPa	1,20 x 1,20 m <sup>2</sup>
• Columns (Story 41 – Story 60); $f_c' = 40$ MPa; $f_y = 400$ MPa	0,9 x 0,9 m <sup>2</sup>
• Floor Diaphragm thickness	0,12 m
• Shearwall (Story 1 – Story 20); $f_c' = 40$ MPa; $f_y = 400$ MPa	0,60 x 10,00 m <sup>2</sup>
• Shearwall (Story 21– Story 40); $f_c' = 30$ MPa; $f_y = 400$ MPa	0,40 x 10,00 m <sup>2</sup>
• Shearwall (Story 41– Story 60); $f_c' = 30$ MPa; $f_y = 400$ MPa	0,30 x 10,00 m <sup>2</sup>



**Figure 6.** Original Ground Acceleration of El Centro 18<sup>th</sup> May 1940 North-South Component

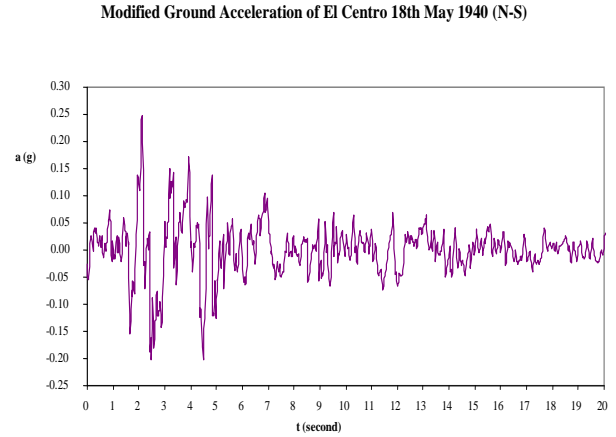

**Figure 7.** Modified Ground Acceleration of El Centro 18<sup>th</sup> May 1940 North-South Component

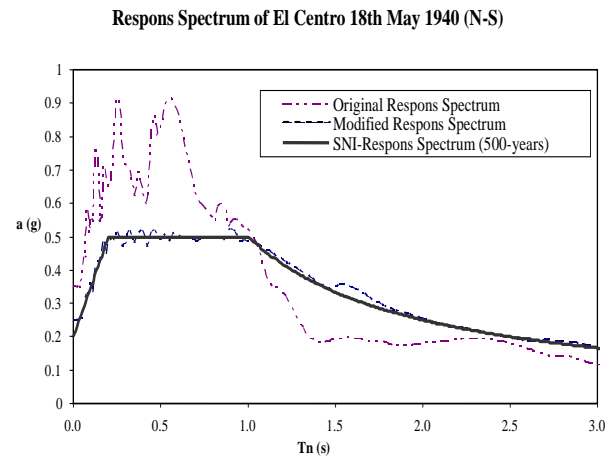

**Figure 8.** Respons Spectrum of El Centro 18<sup>th</sup> May 1940 North-South Component

## Results

The behaviour of the structure in terms of lateral displacements, lateral drifts, and pattern of plastic hinges formation and their damage level are determined. The displacements and lateral story drifts are shown in Figures 9 and 10 respectively. In these Figures, PO and TH indicate static non-linear pushover analysis and dynamic non linear time history analysis respectively. The numbers following either PO or TH are the return period of the earthquake level. It can be seen clearly that results of displacements and lateral story drifts from PO are significantly larger than those from NLTH.

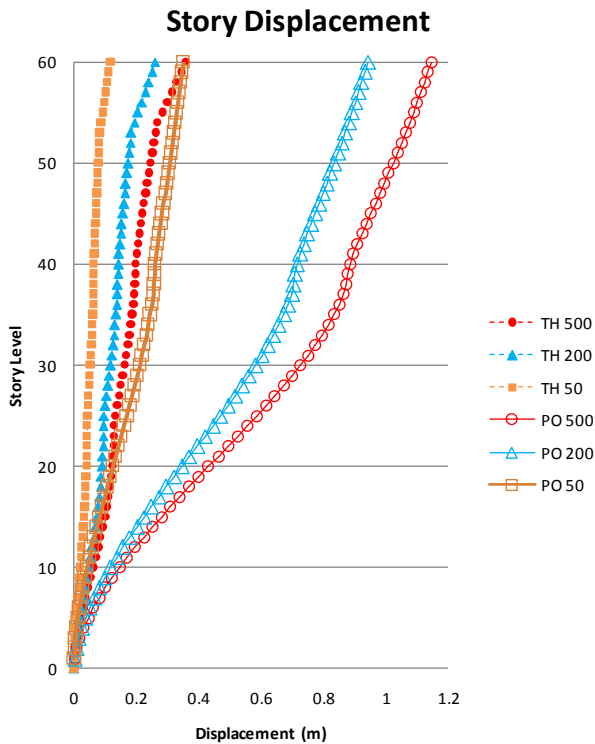

Figure 9. Displacement of the structure

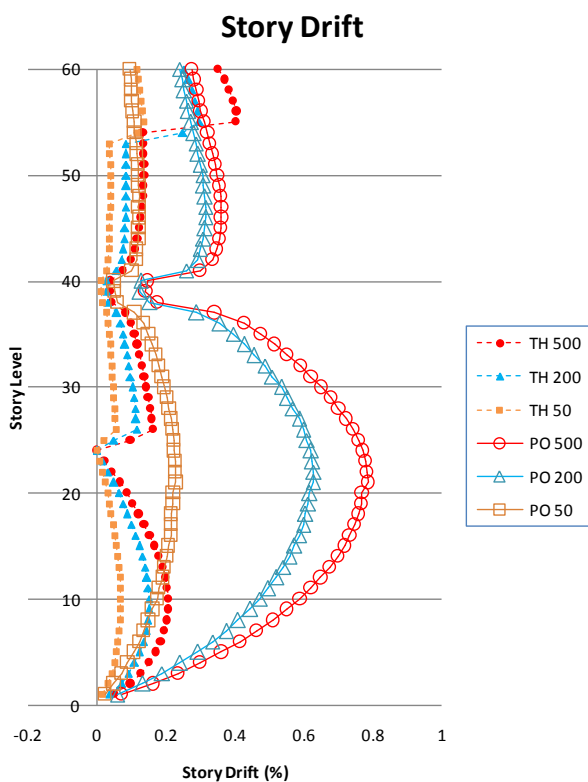

Figure 10. Lateral Story Drift of the structure

Figures 11, 12, and 13 show the plastic hinges formation of the structure as analyzed using static non-linear push over analysis. It can be seen that the plastic hinges mainly develop in beams of stories

below the belt truss. Hinges are also seen at a few beams in stories above the belt truss, a few columns just below the belt truss and at the bottom of the structural walls. On the other hand, results from dynamic non-linear time history analysis (Figures 14, 15, and 16) show plastic hinges mainly above the belt truss, although hinges are also seen at some columns just below the belt truss, and at a few beams and structural wall at bottom stories.

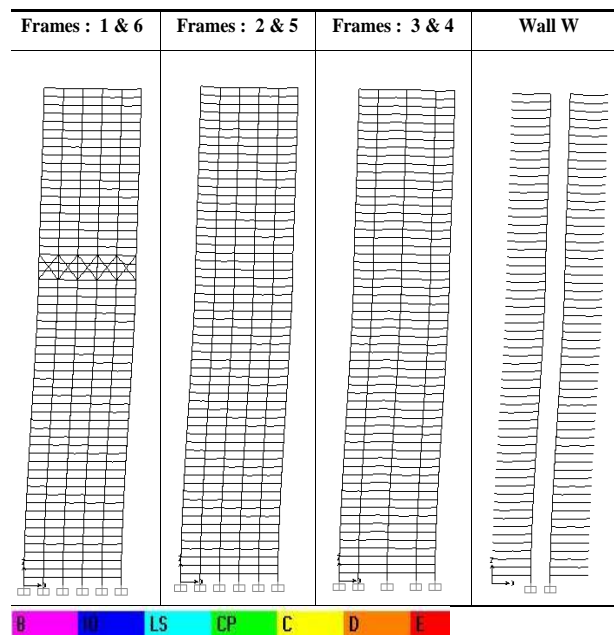

Figure 11. Plastic Hinges Formation Analysed by Static Non-Linear Push Over with 50 Years Return Period Earthquake.

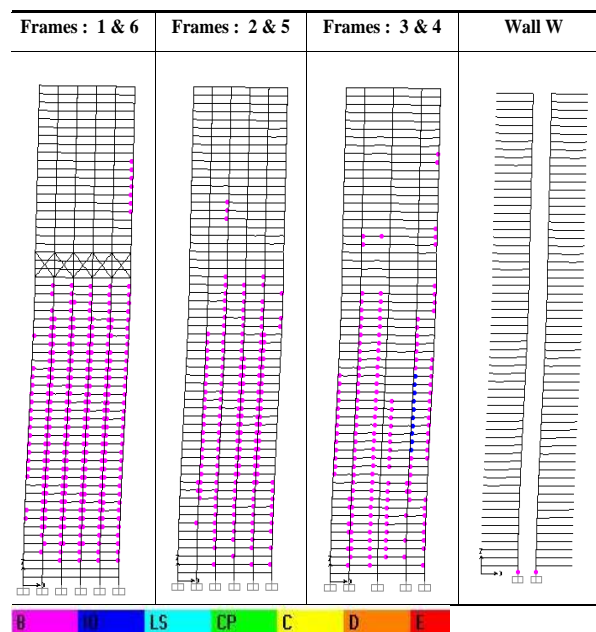
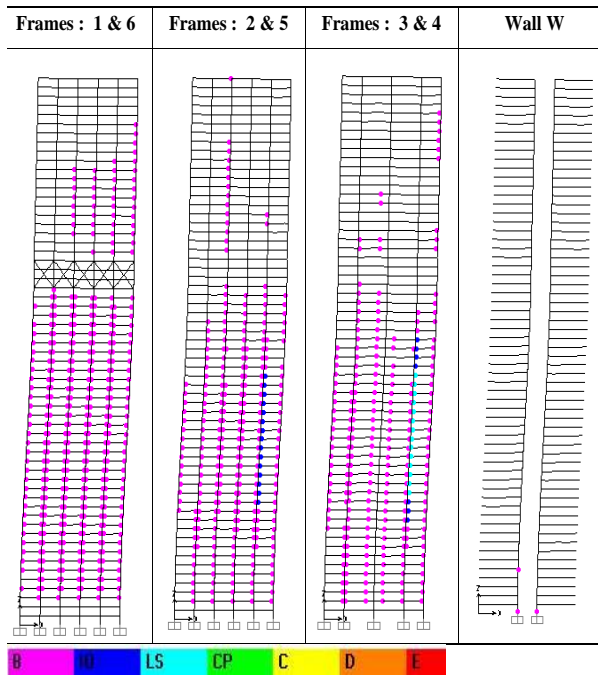
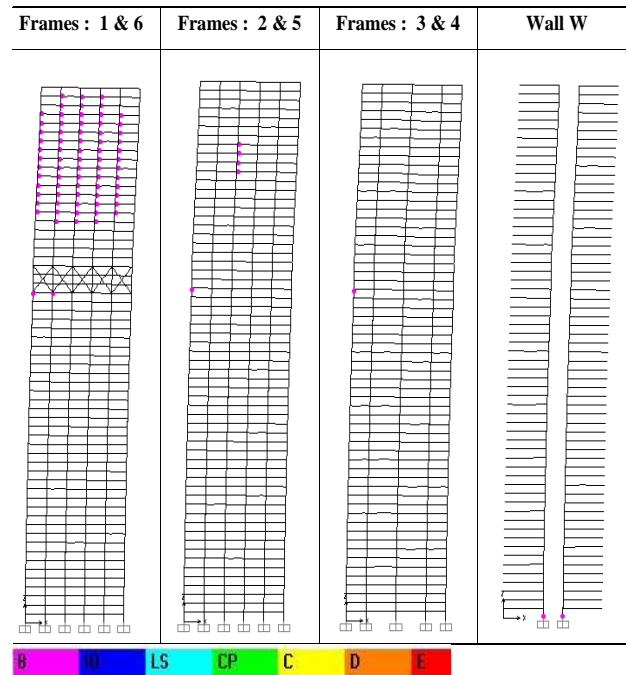

Figure 12. Plastic Hinges Formation Analysed by Static Non-Linear Push Over with 200 Years Return Period Earthquake.



**Figure 13.** Plastic Hinges Formation Analysed by Static Non-Linear Push Over with 500 Years Return Period Earthquake.



**Figure 15.** Plastic Hinges Formation Analysed by Dynamic Non-Linear Time History with 200 Years Return Period Earthquake.

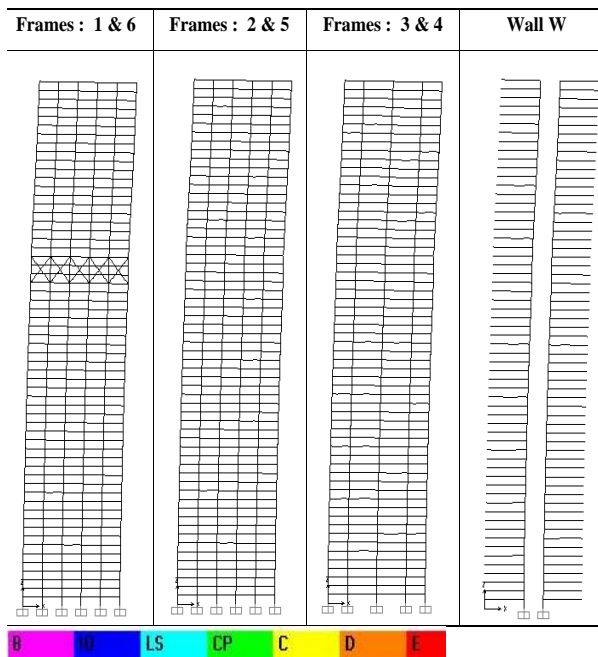

**Figure 14.** Plastic Hinges Formation Analysed by Dynamic Non-Linear Time History with 50 Years Return Period Earthquake.

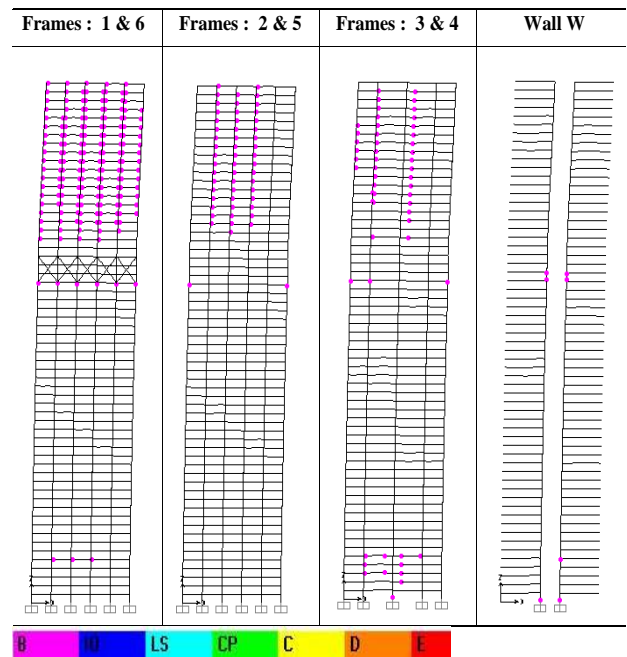

**Figure 16.** Plastic Hinges Formation Analysed by Dynamic Non-Linear Time History with 500 Years Return Period Earthquake.

### Discussion and Conclusions

Static non-linear push over analysis is a simple alternative method in evaluating structure behaviour under dynamic loading. In this study, with the complexity of vertical stiffness distribution with the existence of belt truss, static non-linear push over analysis shows its limitation. Lateral story drifts from dynamic non-linear time history analysis show a more logical results. The lateral story drifts significantly decrease at the level of belt truss and at the story 23rd where overturning moment of shearwall drops (as shown in Figure 17). Dynamic non-linear time history analysis is able to show this behavior but not the static non-linear push over analysis.

In term of damage, static non-linear push over analysis show more plastic hinges developed at the lower part of the building. The dynamic non-linear time history analysis shows smaller lateral displacement due to stiffer lower part of the building. This explains the extremely large displacement difference of both analysis. The performance level of the building according to Asian Concrete Model Code [13] in terms of drift ratio and damage index can be seen in Tables 2 and 3 respectively. The grey shaded area in the Tables indicate the desired performance level of the building.

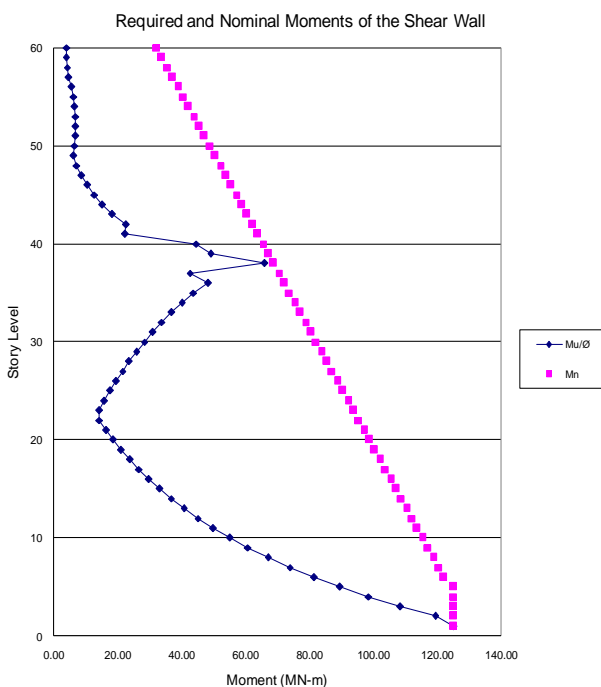

Figure 17. Required and Nominal Moments at Shearwall (Response Spectrum Analysis)

Table 2. Building Performance Level According to Drifts specified by ACMC

Return Period (years)	Performance Level			
	Serviceability Limit State	Damage Control Limit State	Safety Limit State	Unacceptable Limit State
50	PO - TH			
200	TH	PO		
500	TH	PO		
Maximum Drift (%)	0,5	1	2	> 2,00

Table 3. Building Performance Level According to Damage Index specified by ACMC

Return Period (years)	Performance Level				
	First Yield	Serviceability Limit State	Damage Control Limit State	Safety Limit State	Unacceptable Limit State
50	PO-TH				-
200	TH	PO			-
500	TH		PO		-
Maximum Damage Index	>0,1	0,10-0,25	0,25-0,4	0,4-1,00	> 1,00

A more detail observation indicates that maximum damage index at beams is only 0.334, while columns and structural walls show an even smaller ratio (lower than 0.1). It can be concluded that overall performance of the building shows satisfactory results, and no sign of instability. According to this study, the ductility value,  $\mu=3.75$  (equivalent to seismic reduction factor  $R=6$ ) can be used for the considered shearwall frame–belt truss system.

### References

- Nair, R. S., Belt Trusses and Basements as 'Virtual' Outriggers for Tall Buildings, *Engineering Journal, AISC*, Fourth Quarter/1998, pp. 140-146.
- Adhi, A. and Tenggara, W.A., *Pemakaian Belt Truss sebagai Virtual Outrigger*, Undergraduate Thesis. Faculty of Civil Engineering and Planning, Department of Civil Engineering. Petra Christian University, Surabaya, Indonesia, 2000.
- Lumantarna, B., Fransisca, and Rosilawati, Perilaku Belt Truss sebagai Virtual Outrigger, *Proc. HAKI Conference 1999*, September 1999 Jakarta, Indonesia, pp. 101-109.

4. Lumantarna, B., The Effectiveness of Belt Truss As Virtual Outrigger for Tall Building, *Proc. ICCMC/IBST 2001 International Conference on Advanced Technologies in Design, Construction and Maintenance of Concrete Structures*, March 2001 Hanoi, Vietnam, pp. 140-146.
5. Pudjisuryadi, P., Lumantarna, B., Daktilitas Struktur Shearwall–Frame dengan Belt Truss sebagai Virtual Outrigger, *Civil Engineering Dimension*, 8(1), March 2006, pp.41-46.
6. Pudjisuryadi, P., Lumantarna, B., A Preliminary Study on the Ductility of Shear Wall Frame – Belt Truss (Virtual Outrigger) System, *Proc. The Tenth East Asia-Pacific Conference on Structural Engineering & Construction (EASEC-10)*, August 3-5 2006 Bangkok, Thailand, pp. 695-700.
7. Badan Standarisasi Nasional (BSN), Standar Nasional Indonesia (SNI) 03-1726-2002, *Tata Cara Perencanaan Ketahanan Gempa untuk Bangunan Gedung*.
8. Prasetyo, A., Sumendap, H.S., *Studi Lanjut tentang Daktilitas Struktur pada Sistem Shear-wall Frame–Belt Truss sebagai Virtual Outrigger*, Undergraduate Thesis. Faculty of Civil Engineering and Planning, Department of Civil Engineering. Petra Christian University, Surabaya, Indonesia, 2008.
9. Standar Nasional Indonesia (SNI) 03-2847-2002, *Tata Cara Perencanaan Struktur Beton Untuk Bangunan Gedung*.
10. Lumantarna, B., Lukito, M., *RESMAT, Sebuah Program Interaktif untuk Menghasilkan Riwayat Waktu Gempa dengan Sppektrum Tertentu*, *Proc. HAKI Conference 1997*, August 13-14 1997 Jakarta, Indonesia, pp. 128-135.
11. Susila, I.G.M., *Seismic Microzonation and Site Spesific Respones Analysis for Denpasar*, Thesis. Geotechnical Engineering of Graduate Program, Institute of Technology, Bandung, Indonesia, 2000.
12. Habibullah, A., *SAP2000-Linear and Nonlinear Static and Dynamic Analysis and Design of Three-Dimensional Structure*, Computer and Structures, Inc., Berkeley, California, USA, 2006.
13. International Committee on Concrete Model Code. *Asian Concrete Model Code, Level 1 & 2 Documents*, Second Draft. Japan, 1999.