

The Scopus Author Identifier assigns a unique number to groups of documents written by the same author via an algorithm that matches authorship based on a certain criteria. If a document cannot be confidently matched with an author identifier, it is grouped separately. In this case, you may see more than 1 entry for the same author.

Print | E-mail

Anggono, Willyanto

Universitas Kristen Petra, Department of Mechanical Engineering, Surabaya, East Java, Indonesia

Author ID: 55561550300

About Scopus Author Identifier | View potential author matches
Other name formats: Anggono, W.

Follow this Author Receive emails when this author publishes new articles

Get citation alerts

Add to ORCID

Request author detail corrections

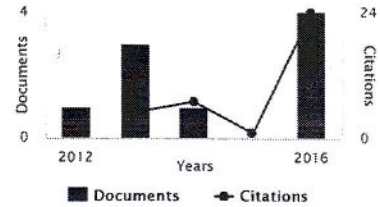

Documents: 9 Analyze author output
Citations: 37 total citations by 16 documents View h-graph
h-index: 4
Co-authors: 14
Subject area: Engineering, Physics and Astronomy View More

9 Documents | Cited by 16 documents | 14 co-authors

9 documents View in search results format Sort on: Date Cited by

Export all | Add all to list | Set document alert | Set document feed

Document Title	Author(s)	Year	Journal/Conference	Citations
Performance of gasoline/LPG BI-fuel engine of manifold absolute pressure sensor (MAPS) variations feedback	Setiyo, M., Waluyo, B., Anggono, W., Husni, M.	2016	ARPN Journal of Engineering and Applied Sciences	1
The influence of CO2 in biogas flammability limit and laminar burning velocity in spark ignited premix combustion at various pressures	Anggono, W., Wardana, I.N.G., Lawes, M., (...), Hamidi, N., Hayakawa, A.	2016	AIP Conference Proceedings	0
The effect of nitrogen on biogas flame propagation characteristic in premix combustion	Anggono, W., Suprianto, F.D., Hartanto, T.I., Purnomo, K., Wijaya, T.P.	2016	AIP Conference Proceedings	0
Effect of carbon dioxide on flame characteristics in biogas external premix combustion	Suprianto, F.D., Anggono, W., Tanoto, M.S.C.	2016	International Journal of Applied Engineering Research	0
Behavior of flame propagation in biogas spark ignited premix combustion with carbon dioxide inhibitor	Anggono, W., Dwiputra Suprianto, F., Wijaya, T.P., Tanoto, M.S.C.	2014	Advanced Materials Research	3
Effect of inhibitors on biogas laminar burning velocity and flammability limits in spark ignited premix combustion	Anggono, W., Wardana, I.N.G., Lawes, M., Hughes, K.J.	2013	International Journal of Engineering and Technology	6
Laminar burning velocity and flammability characteristics of biogas in spark ignited premix combustion at reduced pressure	Anggono, W., Wardana, I., Lawes, M., (...), Wahyudi, S., Hamidi, N.	2013	Applied Mechanics and Materials	7
Biogas laminar burning velocity and flammability characteristics in spark ignited premix combustion	Anggono, W., Wardana, I.N.G., Lawes, M., (...), Hamidi, N., Hayakawa, A.	2013	Journal of Physics: Conference Series	10
Laminar burning characteristics of biogas-air mixtures in spark ignited premix combustion	Anggono, W., Wardana, I.N.G., Lawes, M., (...), Wahyudi, S., Hamidi, N.	2012	Journal of Applied Sciences Research	10

Author History

Publication range: 2012 - Present

References: 75

Source history:

- Advanced Materials Research View documents
- AIP Conference Proceedings View documents
- International Journal of Engineering and Technology View documents

View More

Show Related Affiliations

Display 20 results per page

Page 1

Top of page

The data displayed above is compiled exclusively from articles published in the Scopus database. To request corrections to any inaccuracies or provide any further feedback, please contact us (registration required). The data displayed above is subject to the privacy conditions contained in the privacy policy.



AIP Conference Proceedings

37

H Index

Country	United States
Subject Area	Theoretical Astronomy
Subject Category	Physics and Astronomy (miscellaneous)
Publisher	
Publication type	Conferences and Proceedings
ISSN	0094243X
Coverage	-

Scope AIP Conference Proceedings report findings presented at many of the most important scientific meetings around the world. Published proceedings are valuable as topical status reports providing quick access to information before it appears in the traditional journal literature. (continued)

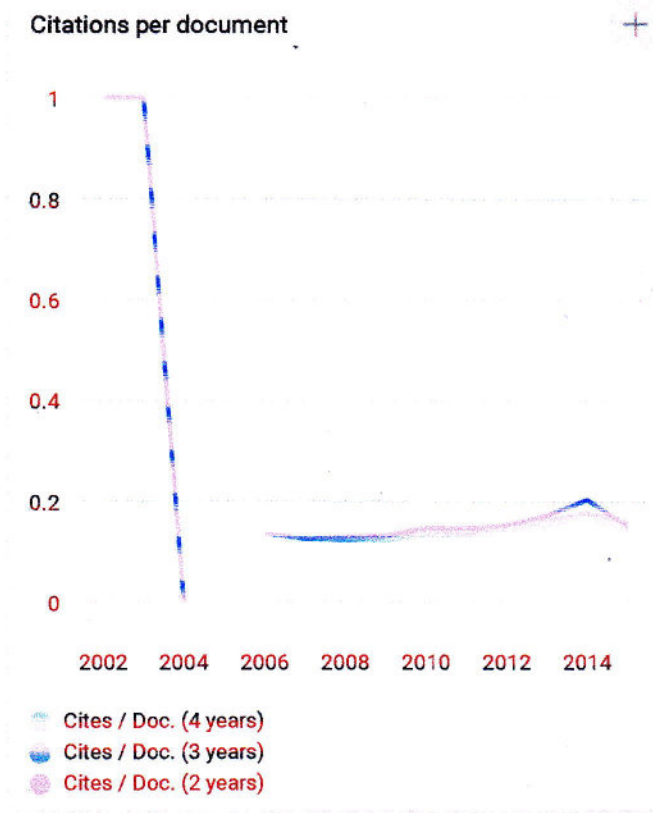
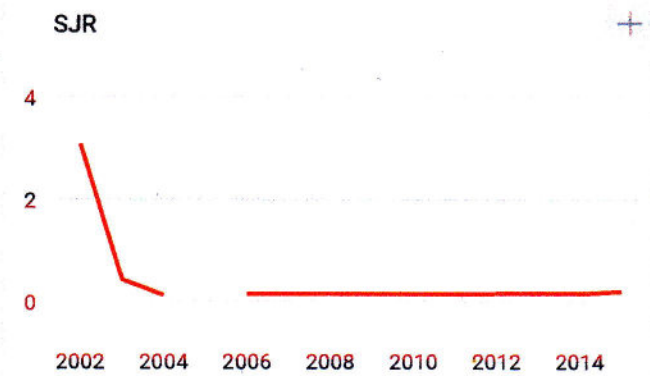

Follow us on Twitter

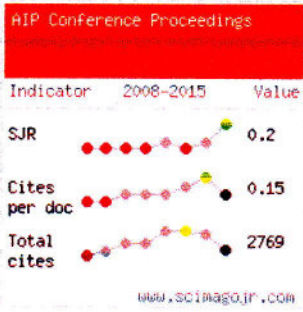
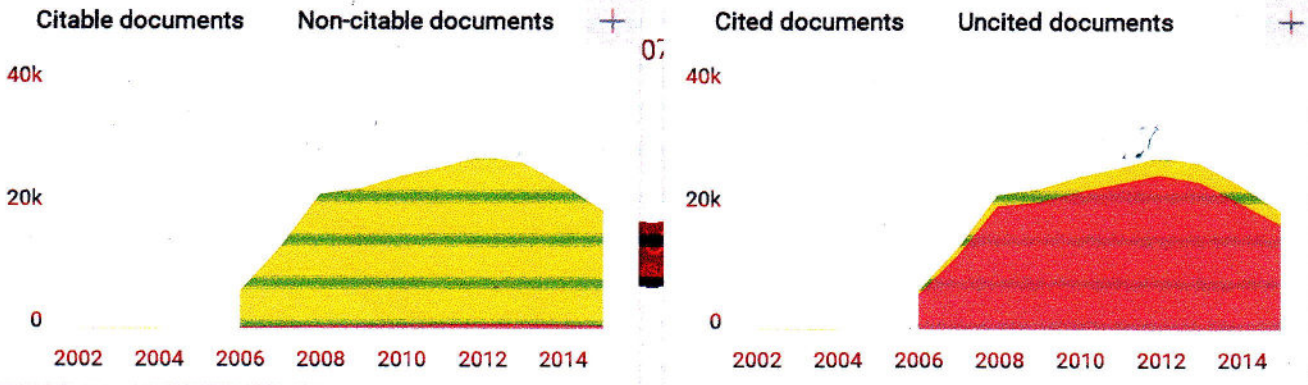

← Show this widget in your own website

Just copy the code below and paste within your html code:

```
<a href="http://www.scima
```

ACCESS NOW!

CODATA RECOMMENDED VALUES OF THE
FUNDAMENTAL PHYSICAL CONSTANTS: 2014



AIP | Journal of Physical and
Chemical Reference Data

AIP Conference Proceedings



BUY PRINT BOOKS

HOME BROWSE INFO FOR AUTHORS

 SIGN UP FOR ALERTS

FOR ORGANIZERS

AIP | Conference
Proceedings

Organizing a conference?

Enjoy fast, cost-effective publication of your meeting's key research!

AIP Conference Proceedings report findings presented at many of the most important scientific meetings around the world. Published proceedings are valuable as topical status reports providing quick access to information before it appears in the traditional journal literature.

Today, AIP Conference Proceedings contain over 100,000 articles published in 1,700+ proceedings, and is growing by 100 volumes every year. This substantial body of scientific literature is testament to our 40-year history as a world-class publishing partner, recognized internationally and trusted by conference organizers world-wide. Whether you are planning a small specialist workshop or organizing the largest international conference contact us, or [read these testimonials](#), to find out why so many organizers publish with AIP Conference Proceedings.

• Most Recent

FORTHCOMING TITLES

For more information
regarding our schedule
of forthcoming proceedings

SEE MORE

• Most Read

JAN 13 2017

**Cesium
pentazolate: A new
nitrogen-rich
energetic material**

APR 13 2016

**Green synthesis of
nanoparticles: Their
advantages and
disadvantages**

FEB 17 2015

- 1698 (2016) ▾
- 1703 (2015) ▾
- 1702 (2015) ▾
- 1697 (2015) ▾
- 1699 (2015) ▾
- 1700 (2015) ▾
- 1692 (2015) ▾
- 1695 (2015) ▾
- 1693 (2015) ▾
- 1691 (2015) ▾
- 1689 (2015) ▾
- 1694 (2015) ▾

Free · March 2016

Size dependence lattice thermal conductivity for Si nanofilm

Hawkar T. Taha, and Abdulrahman Kh. Allassafee

AIP Conference Proceedings **1718**, 090005 (2016); <http://doi.org/10.1063/1.4943344>

[SHOW ABSTRACT](#) [PDF](#) [ADD TO FAVORITES](#) [SHARE](#) [EXPORT CITATION](#)

PHYSICS AND RENEWABLE ENERGY

Free · March 2016

The effect of nitrogen on biogas flame propagation characteristic in premix combustion

Willyanto Anggono, Fandi D. Suprianto, Tan Ivan Hartanto, Kenny Purnomo, and Tubagus P. Wijaya

AIP Conference Proceedings **1718**, 100001 (2016); <http://doi.org/10.1063/1.4943345>

[SHOW ABSTRACT](#) [PDF](#) [ADD TO FAVORITES](#) [SHARE](#) [EXPORT CITATION](#)

**Preface: 5th International Conference and Workshop on Basic and Applied Sciences
(5th ICOWOBAS) 2015**

Citation: [AIP Conference Proceedings](#) **1718**, 010001 (2016); doi: 10.1063/1.4943308

View online: <http://dx.doi.org/10.1063/1.4943308>

View Table of Contents: <http://aip.scitation.org/toc/apc/1718/1>

Published by the [American Institute of Physics](#)

Preface: 5th International Conference and Workshop on Basic and Applied Sciences.

Foreword from Chairman of 5th ICOWOBAS 2015

Ladies and Gentleman,

The 5th International Conference and Workshops on the Basic and Applied Sciences (ICOWOBAS) is organized of existing collaborations between Airlangga University, Universiti Teknologi Malaysia and Salahaddin-Hawler University (Erbil, Iraqi Kurdistan) in order to promote the development of sciences and their prospect of application in industry and medical devices. The program of this activity are the scientific program involves the presentation of the paper and poster in the area of chemistry, biology, physics, mathematics and their applications. It also conducts the workshop program was presented the current issues in optical instrumentation. Thus invited many participants as academic researchers, scientists, industrial professionals, government officers, students and other participants. The meeting intends to bring together researcher, scientists and scholars to exchange and share their experiences, new ideas, research novelties in related fields and discuss the practical challenges and the solutions adopted.

The AIP proceedings hold the full papers presented at the 5th ICOWOBAS. The conference took place in Surabaya (Indonesia) at the Garuda Mukti Room, Kampus C Universitas Airlangga, October 16th - 17th, 2015, and the workshop was conducted at the Faculty of Science and Technology, Airlangga University, October 15th, 2015.

The conference included: Prof. Dr. Retna Apsari (Universitas Airlangga, Indonesia) as invited speaker. In total, we received 152 abstracts for oral and 29 posters, and 46 full paper selected in AIP proceeding. As the acceptance rates illustrates the competition is stiff, and the accepted submission reflected high rates of reviewer enthusiasm. By design, these papers have been through peer-review process and they are almost accepted.

ICOWOBAS is a lot of work. We could not have done it without help from many people. We would especially like to thank: Scientific board of ICOWOBAS, for inviting us to chair the meeting; The Rector of Airlangga University, for supporting us to conduct the conference; our colleagues in the Faculty of Science and Technology, Airlangga University, for their support in the conference; the local committee, for organizing and handling the conference; the many reviewers, for providing professional reviews; our sponsor: Vitalong C and DGHE through Airlangga University funding.

Surabaya, February 2016

Dr. Moh. Yasin

Scitation

Contact

AIP Publishing

1305 Walt Whitman Road
Suite 300
Melville, NY 11747-4300
+1 516-576-2200 (M-F, 8:30 am - 5:00 pm U.S. Eastern)

[Directions](#)

Customer Service: help@scitation.org

Institutional Sales: sales@aip.org

Rights and Permissions: rights@aip.org

Press: press@aip.org

LIVE SUPPORT
Offline - [Click to email](#)

Live Chat Software

by Velaro

* Request Type:

Customer Service Query Technical Support Editorial Feedback

* Name

* Email

* Account Number

Journal:

Committees: 5th International Conference and Workshop on Basic and Applied Sciences (5th ICOWOBAS) 2015

Citation: [AIP Conference Proceedings](#) **1718**, 010002 (2016); doi: 10.1063/1.4943309

View online: <http://dx.doi.org/10.1063/1.4943309>

View Table of Contents: <http://aip.scitation.org/toc/apc/1718/1>

Published by the [American Institute of Physics](#)

Committees

Scientific committees:

1. Prof. Dr. Stephen G. Pyne (University of Wollongong, Australia)
2. Prof. Dr. Sugeng Triwahyono (Universiti Teknologi Malaysia, Malaysia)
3. Prof. Dr. Sulaiman W. Harun (University of Malaya, Malaysia)
4. Assoc. Prof. Dr. Yhosiaki Takaya (Meijo University, Japan)
5. Prof. Dr. Retna Apsari (Universitas Airlangga, Indonesia)
6. Dr. Fatmawati, M.Si. (Universitas Airlangga, Indonesia)
7. Prof. Dr. Afaf Baktir, MS. (Universitas Airlangga, Indonesia)
8. Prof. Dr. Suhariningsih (Universitas Airlangga, Indonesia)
9. Prof. Dr. Ir. Agoes Soegianto, DEA. (Universitas Airlangga, Indonesia)
10. Prof. Dr. Bambang Irawan, M.Sc. (Universitas Airlangga, Indonesia)
11. Dr. Y. Sri Wulan Manuhara, M. Si. (Universitas Airlangga, Indonesia)
12. Dr. Pratiwi Pudjiastuti, M.Si (Universitas Airlangga, Indonesia)
13. Dr. Muji Harsini, M.Si (Universitas Airlangga, Indonesia)
14. Dr. Miswanto, M.Si. (Universitas Airlangga, Indonesia)
15. Dr. Nur Chamidah, M.Si. (Universitas Airlangga, Indonesia)
16. Dr. Windarto, M.Si. (Universitas Airlangga, Indonesia)
17. Dr. Mochamad Zakki Fahmi (Universitas Airlangga, Indonesia)

Organizing Committees:

1. Dr. Moh. Yasin (Universitas Airlangga, Indonesia)
2. Prof. Dr. Hery Purnobasuki (Universitas Airlangga, Indonesia)
3. Dr. Eridani, M.Si. (Universitas Airlangga, Indonesia)
4. Dr. Hewa Y Abdullan (Salahaddin-Hawler University, Erbil, Iraqi Kurdistan)
5. Prof. Dr. Wan Aini Ibrahim (Universiti Teknologi Malaysia, Malaysia)



CERTIFICATE

Fifth International Conference and Workshops
on Basic and Applied Sciences 2015

This certificate is awarded to:

Wilyanto Anggono

in recognition of his / her contribution as a

Oral Presenter

in the Fifth International Conference and Workshops on Basic and Applied Sciences ~ ICOWOBAS 2015
on October 16th -17th, 2015, Kampus C UNAIR Surabaya, East Java, Indonesia.

Supported and organized by Universitas Airlangga, Universiti Teknologi Malaysia and
Salahaddin University-Erbil.

Dean of the Faculty of Science and Technology
Universitas Airlangga



Prof. Win Darmanto, M.Si., Ph.D.

Program Chair



Dr. Moh. Yasin, M.Si.



UNAIR
UNIVERSITAS AIRLANGGA



UTM
UNIVERSITI TEKNOLOGI MALAYSIA



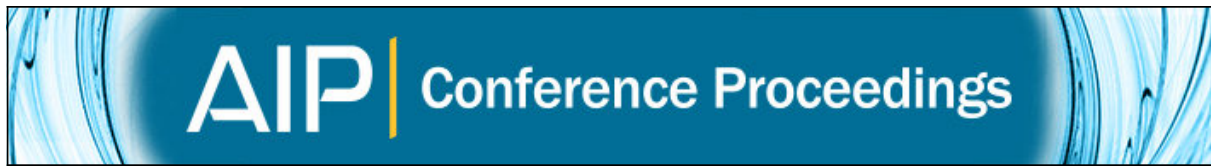

The effect of nitrogen on biogas flame propagation characteristic in premix combustion

Willyanto Anggono, Fandi D. Suprianto, Tan Ivan Hartanto, Kenny Purnomo, and Tubagus P. Wijaya

Citation: [AIP Conference Proceedings](#) **1718**, 100001 (2016); doi: 10.1063/1.4943345

View online: <http://dx.doi.org/10.1063/1.4943345>

View Table of Contents: <http://scitation.aip.org/content/aip/proceeding/aipcp/1718?ver=pdfcov>

Published by the [AIP Publishing](#)

Articles you may be interested in

[Turbulent premixed combustion in V-shaped flames: Characteristics of flame front](#)

Phys. Fluids **25**, 055107 (2013); 10.1063/1.4807073

[Microwave plasma-assisted premixed flame combustion](#)

Appl. Phys. Lett. **89**, 141501 (2006); 10.1063/1.2358213

[Effects of initial radius on the propagation of premixed flame kernels in a turbulent environment](#)

Phys. Fluids **18**, 055102 (2006); 10.1063/1.2196092

[Combustion Noise from a Turbulent Premixed Methane Flame](#)

J. Acoust. Soc. Am. **64**, 1734 (1978); 10.1121/1.2033258

[Combustion noise from a turbulent premixed methane flame](#)

J. Acoust. Soc. Am. **61**, S25 (1977); 10.1121/1.2015504

The Effect of Nitrogen on Biogas Flame Propagation Characteristic in Premix Combustion

Willyanto Anggono^{1,a)}, Fandi D Suprianto², Tan Ivan Hartanto³, Kenny Purnomo⁴
and Tubagus P Wijaya⁵

^{1,2,3,4,5}Mechanical Engineering Department, Petra Christian University, Surabaya, Indonesia

^{a)}Corresponding author: willy@petra.ac.id

Abstract Biogas is one of alternative energy and categorized as renewable energy. The main sources of biogas come from animal waste, garbage, and household waste that are organic waste. Primarily, over 50% of this energy contains methane (CH₄). The other substances or inhibitors are nitrogen and carbon dioxide. Previously, carbon dioxide effect on biogas combustion is already experimented. The result shows that carbon dioxide reduces the flame propagation speed of biogas combustion. Then, nitrogen as an inhibitor obviously also brings some effects to the biogas combustion, flame propagation speed, and flame characteristics. Spark ignited cylinder is used for the premixed biogas combustion research. An acrylic glass is used as the material of this transparent cylinder chamber. The cylinder is filled with methane (CH₄), oxygen (O₂), and nitrogen (N₂) with particular percentage. In this experiment, the nitrogen composition are set to 0%, 5%, 10%, 20%, 30%, 40%, and 50%. The result shows that the flame propagation speed is reduced in regard to the increased level of nitrogen. It can also be implied that nitrogen can decrease the biogas combustion rate.

Keywords: Biogas, flame propagation, nitrogen, premix combustion, sustainable energy.

INTRODUCTION

Biogas as a source of alternative energy is categorized as renewable energy. Biogas consists of several chemical substances such as flammable methane gas (CH₄), carbon dioxide (CO₂), and nitrogen (N₂) [1-8]. Nitrogen in this compound behaves as an inhibitor. Inhibitors are resulting in reducing the laminar burning velocity [1-5].

This research is conducted to see the effects of flame propagation speed, and flame characteristics of biogas combustion. Flame characteristics are useful to create several biogas combustion applications particularly for internal combustion. One of the flame characteristics is laminar burning velocity. The laminar burning velocity directly affects the pressure development. Hence, it is used to understand the combustion process in the internal combustion engine for reducing the emissions. The experiment is conducted in both room temperature and atmospheric condition using stoichiometric standards. Stoichiometric standard is a state where the fuel is ideally and completely burnt. This experiment is conducted at known rates of pressure, temperature, and volume so that ideal gas can be assumed to this experiment. Then, molar mass of each gas is used to calculate the mass ratio [9-13].

Flame propagation plays a crucial role in the success of combustion ignition. For example, the data of flame speed is used to determine the internal combustion chamber material and other parts that are connected to the chamber. Theoretically, during the methane explosion, the biogas combustion products compress the medium in front of the flame front surface also create a compression wave caused by the chemical reaction, the flame propagates very quick. As the result, the density, pressure and temperature sharply rises to form a detonation wave [14-15].

EXPERIMENTAL SETUP AND METHODS

The combustion chamber from transparent acrylic cylinder with 300 mm of height and 70 mm of outer diameter was used in this experiment. The thickness of this acrylic cylinder is 5 mm thus the inner diameter is 60 mm. The schematic diagram of the combustion bomb system is shown in Figure 1.

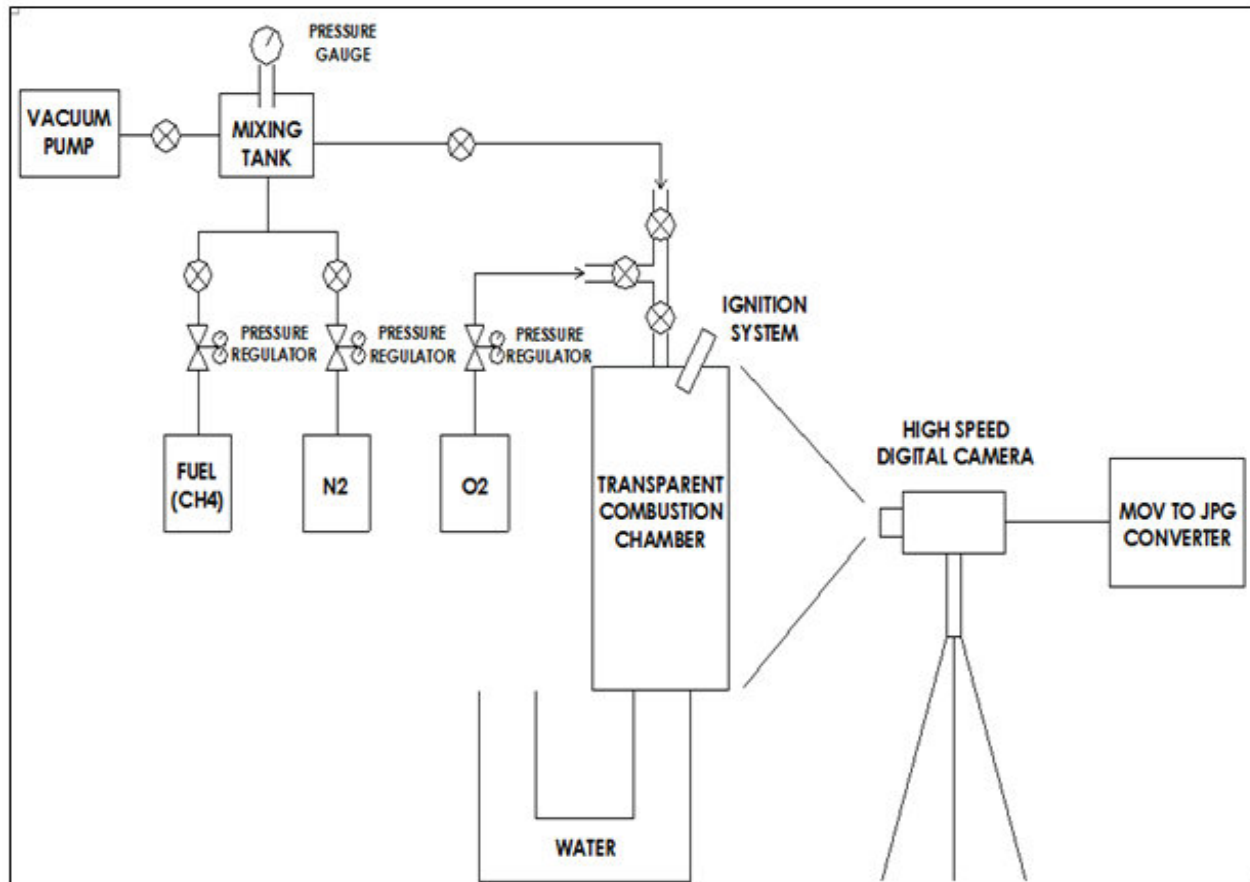

FIGURE 1. Experimental setup diagram

The combustion chamber is filled with premixed fuel-air with various nitrogen contents in biogas. This experiment is conducted in room temperature, atmospheric condition and stoichiometric standard ($\phi=1$). High speed camera was used to record the all combustion process. Then, the video is converted to obtain the picture files so that the flame propagation speed differences can be measured.

RESULT AND DISCUSSION

The biogas combustion experiment had already been done by the presence of specific nitrogen inhibitor as stated before. These pictures have differences each other related to the nitrogen composition. In figure 2, there are 2 pictures for each nitrogen composition. Those 2 pictures show the first and second frame of the video which the combustion occurs.

From the pictures in figure 2, it can be seen that picture 1 is the pure methane combustion result without nitrogen inhibitor on it. Then, picture 7 is biogas combustion result that contains the most nitrogen inhibitor. Undoubtedly, it also showed that there is flame length different gradient from picture 1 to 7. Picture 1 have the biggest biogas flame length difference but on the other hand, picture 7 have the shortest biogas flame length difference which contains 50% of nitrogen inhibitor. The higher nitrogen (N_2) inhibitor compositions in biogas combustion, the shorter biogas flame length difference result.

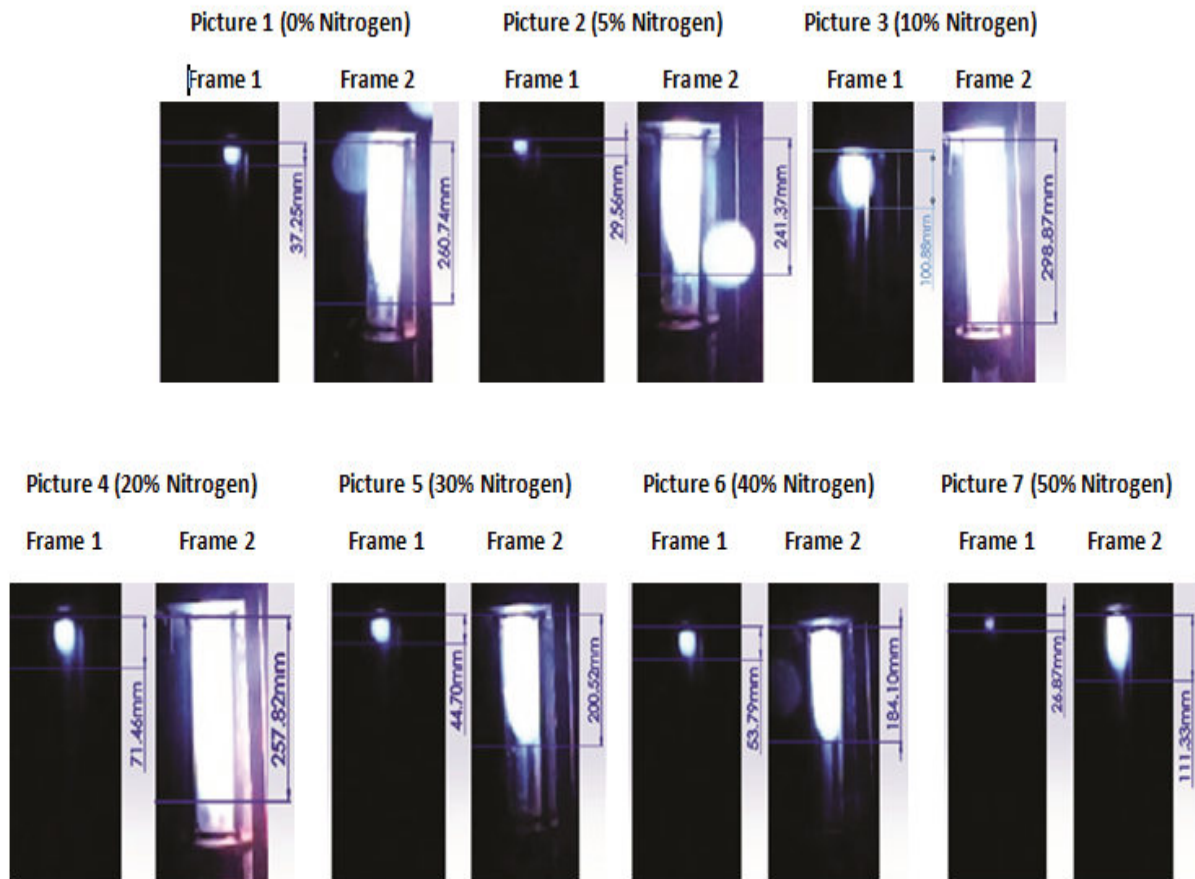

FIGURE 2. Biogas flame propagation

TABLE 1. Biogas flame propagation speed

Picture Number	N ₂ (%)	Frame 1 (mm)	Frame 2 (mm)	Frame 2 – Frame 1 (mm)	Flame Diffusion Speed (m/s)
1	0	37.25	260.74	223.49	6.77
2	5	29.56	241.37	211.81	6.42
3	10	100.88	298.87	197.99	6.00
4	20	71.46	257.82	186.36	5.65
5	30	44.70	200.52	155.82	4.72
6	40	53.79	184.10	130.31	3.95
7	50	26.87	111.33	84.46	2.56

The results of biogas combustion flame are measured for every nitrogen (N₂) composition and the length of the biogas flame can be obtained. The flame recording time is also determined at the same time which is in the first and second frame after the flame appears in the video. The biogas flame propagation speed that had already been experimented is shown in Table 1. First, the 0% biogas addition delivers the fastest flame propagation speed which is 6.77 m/s. Then, flame propagation speed is reduced based on the nitrogen inhibitor enhancement to the biogas combustion. The flame propagation speed of 5%, 10%, 20%, 30%, and 40% nitrogen inhibitors are 6.42 m/s, 6.00 m/s, 5.65 m/s, 4.72 m/s, and 3.95 m/s respectively. Eventually, the latest flame propagation speed is 2.56 m/s which have 50% of nitrogen inhibitor in the reactant.

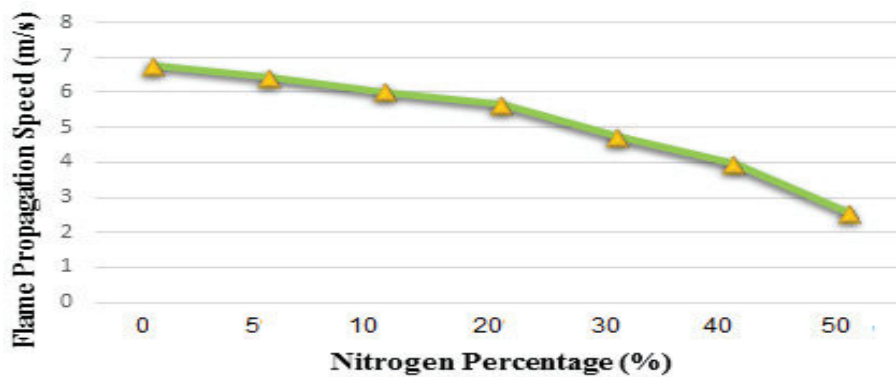

FIGURE 3. The effects of nitrogen inhibitor on flame propagation speed

Figure 3 shows that trend of flame propagation speed is declining corresponding to the addition of nitrogen inhibitor. Nitrogen as biogas inhibitor has the ability to reduce the oxidation chemical reaction during the combustion. The existence of nitrogen here also reduces the amount of methane as the primary fuel so that the flame propagation speed is hampered and becomes slower. Furthermore, the reactive compounds in this reaction are also reduced with the nitrogen addition.

CONCLUSION

The biogas combustion which contain specific methane (CH_4), oxygen (O_2), and nitrogen (N_2) had already been done in spark ignited combustion chamber. The transparent acrylic chamber is used to represent combustion process in internal combustion engine. The nitrogen inhibitor is ranged from 0% to 50% using stoichiometric standard ($\phi=1$). The flame propagation speed with 0% of nitrogen inhibitor has 6.77 m/s of propagation speed. Contrarily, the flame propagation speed of the most nitrogen inhibitor (50%) is 2.56 m/s. The result indicates that nitrogen inhibitor in biogas reduces combustion rate. The more nitrogen concentration in the chemical reaction proportion also cuts down the methane (CH_4) fuel amount. If the combustion rate decreased, the thermodynamics efficiency of internal combustion engine application would decline as well. Hence, flame propagation speeds play a crucial role in the success of combustion ignition.

ACKNOWLEDGMENTS

Thanks to Direktorat Jendral Pendidikan Tinggi Kementerian Pendidikan Nasional Republik Indonesia (Hibah Penelitian Fundamental 2014-2015 and Hibah Iptek bagi Masyarakat 2015) and Petra Christian University Indonesia which have supported this research.

REFERENCES

1. W. Anggono, et al., [Advanced Materials Research](#) 1044-1045, 251-254 (2014).
2. W. Anggono, et al., [International Journal of Engineering and Technology](#) 5, 4980-4987 (2014).
3. W. Anggono, et al., [Journal of Physics: Conference Series](#) 423, 1-7 (2013).
4. W. Anggono, et al., [Applied Mechanics and Materials](#) 376, 79-85 (2013).
5. W. Anggono, et al., [Journal of Applied Sciences Research](#) 8, 4126-4132 (2012).
6. W. Anggono, et al., Experimental and numerical simulation on biogas flame propagation characteristic in spark ignition premixed combustion, 3rd, International Conference on Engineering and ICT, 2012, pp. 290-294.
7. T. Bond, et al., [Energy for Sustainable Development](#) 15, 347-354 (2011).
8. N. Ilminnafik, et al., [International Journal of Academic Research](#) 3, 705-708 (2011).
9. L. Gillespie, et al., Aspects of laminar and turbulent burning velocity relevant to SI engines, SAE Paper Series, 2000.
10. X. J. Gu, et al., [Combustion and Flame](#) 121, 41-58 (2000).

11. D. Bradley, et al., [Combustion and Flame](#) 115, 126–144 (1998).
12. C. Serrano, et al., [International Journal of Hydrogen Energy](#) 33, 851-862 (2008).
13. S. R. Turns, *An introduction to combustion: concepts and applications*, McGraw-Hill, 2000.
14. C. Heeger, et al., [Proceedings of the Combustion Institute](#) 32, 2957–2964 (2009).
15. Q. Ma, et al., [Journal of Loss Prevention in the Process Industries](#) 34, 30-38 (2015).