

Journal of Telecommunication, Electronic and Computer Engineering (JTEC)

ISSN: 2180-1843, eISSN: 2289-8131

Journal of Telecommunication, Electronic and Computer Engineering (JTEC) is a peer-reviewed journal published by the Faculty of Electronic and Computer Engineering (FKEKK), Universiti Teknikal Malaysia Melaka (UTeM). Aiming to disseminate the latest development and achievements in scientific research, this journal serves as a platform for scholars and researchers to share their original and profound research in the fields related to Telecommunication, Electronic and Computer Engineering.

JTEC is currently abstracted and indexed in **SCOPUS (Q4)**, **ASEAN Citation Index (ACI)**, **Google Scholar**, **Malaysian Journal Management System (MYJurnal)** and **Malaysian Citation Index (MYCite)**.



0.44 2017 CiteScore

24th percentile
 Powered by **Scopus**

USER

Username
 Password
 Remember me

NOTIFICATIONS

- [View](#)
- [Subscribe](#)

JOURNAL CONTENT

Search
 All

Browse

- [By Issue](#)
- [By Author](#)
- [By Title](#)
- [Other Journals](#)
- [Categories](#)

FONT SIZE

INFORMATION

- [For Readers](#)
- [For Authors](#)
- [For Librarians](#)



Vol 10, No 2-3

Technology Innovation in Electrical, Electronics and Information Technology

Chief Editor: Felix Pasila

Editors: Yusak Tanoto, Resmana Lim, Murtiyanto Santoso

Table of Contents

Articles

Corrosion Protection of Offshore Wind Energy Constructions in Germany: Challenges and Approaches	PDF
<i>P. Plagemann, A. Momber</i>	1-4
Design of Robotic Arm Controller based on Internet of Things (IoT)	PDF
<i>Mohamad Khairi Ishak, Muhammad Izzat Roslan, Khairul Anuar Ishak</i>	5-8
Optimum Allocation of Reactive Power Sources for Voltage Stability Improvement and Loss Minimization in Power Distribution Systems	PDF
<i>Abraham Lomi, F. Yudi Limpraptono</i>	9-13
OBD-II-Based Vehicle Management Over GPRS Wireless Network for Fleet Monitoring and Fleet Maintenance Management	PDF
<i>Hartono Pranjoto, Lanny Agustine, Mimi Mereditha</i>	15-18
Emotion Recognition using cvxEDA-Based Features	PDF
<i>H. Ferdinando, E. Alasaarela</i>	19-23
Forecasting System Approach for Stock Trading with Relative Strength Index and Moving Average Indicator	PDF
<i>Yulius Hari, Lily Puspa Dewi</i>	25-29
Hybrid PRoPHET-Epidemic Routing Protocol for Optimizing Possibility of Sending Messages in Remote Fishermen Residential Area	PDF
<i>F.X. Ariwibisono, Achmad Basuki, Fatwa Ramdani</i>	31-36
Study of Static Under Frequency Load Shedding On IEEE 3 Generators 9 Bus System Caused of Transient Condition	PDF
<i>Irrine Budi Sulistiawati, Aga Dia Priasmoro, Abraham Lomi, Ardyono Priyadi</i>	37-42
Human Arm Movement Detection Using Low-Cost Sensors for Controlling Robotic Arm	PDF
<i>A. Soetedjo, I.K. Somawirata, A. Irawan</i>	43-46
WebGIS Application of Geospatial Technology for Tourist Destination in Malang	PDF
<i>Dafid Bayu Firmansya, Fatwa Ramdani, Herman Tolle</i>	47-51
Information Systems Adoption among SMEs in Developing Country: The Case of Gerbang Kertasusila	PDF
<i>Trianggoro Wiradinata</i>	53-59
Prototype of Demand Response Controller for Demand Side Management on Home Electricity using Particle Swarm Optimization Algorithm	PDF
<i>Djoni Haryadi Setiabudi, Michael Santoso, Iwan Njoto Sandjaja, Yusak Tanoto</i>	61-66
Indonesian Batik Image Classification Using Statistical Texture Feature Extraction Gray Level Co-occurrence Matrix (GLCM) and Learning Vector Quantization (LVQ)	PDF
<i>Nafik'ah Yunari, Eko Mulyanto Yuniarno, Mauridhi Hery Purnomo</i>	67-71
Improvement of Voltage Stability due to Integration of the Celukan Bawang Power Station to the Bali 16-bus System	PDF
<i>I Made Wartana, Ni Putu Agustini</i>	73-77
Remote Spectrum Analyzer based on Web Software Defined Radio for Use in Telecommunication Engineering Remote Laboratory	PDF
<i>F. Yudi Limpraptono, Eko Nurcahyo</i>	79-82
Web-GIS Application using Multi-Attribute Utility Theory to Classify Accident-Prone Roads	PDF
<i>Anik Vega Vitianingsih, Dwi Cahyono, Achmad Choiron</i>	83-89
The Development of System Dynamics Model to Increase National Sugar Fulfillment Ratio	PDF
<i>E. Suryani, R.A. Hendrawan, E. Taufik, I. Muhandhis, L.P. Dewi</i>	91-96
Implementation of Mamdani and Sugeno Method for Load Forecasting: A Case Study of Malang City	PDF
<i>Yusuf Ismail Nakhoda, Ni Putu Agustini, Ikhzanul Bagus Ariyanto, Abraham Lomi</i>	97-103
Geographic Information Retrieval using Query Aware Document Ranking Method Case Study for Surakarta	PDF
<i>Viny Christanti M, Steven Tionardi, Ery Dewayani</i>	105-111
Electrolysis Synthesis and Characterization Properties of Nickel Oxide	PDF

USER

Username
 Password
 Remember me

NOTIFICATIONS

- [View](#)
- [Subscribe](#)

JOURNAL CONTENT

Search

Browse

- [By Issue](#)
- [By Author](#)
- [By Title](#)
- [Other Journals](#)
- [Categories](#)

FONT SIZE

INFORMATION

- [For Readers](#)
- [For Authors](#)
- [For Librarians](#)

Nanoparticle	
<i>Yanatra Budi Pramana, Yunia Dwie Nurcahyanie, Muhamad Abdul Jumali, Rhenny Ratnawati, Sugito Sugito</i>	113-116
A Preliminary Study of Technical Feasibility for Mobile Phone Remanufacturing in Indonesia	PDF
<i>Yopi Y. Tanoto, Shu-San Gan, Didik Wahjudi, Juliana Anggono</i>	117-121
Improving Image Classification using Fuzzy Neural Network and Backtracking Algorithm	PDF
<i>Abdul Haris Rangkuti, Ayuliana Ayuliana, Muhammad Fahri</i>	123-128
Enhancing Students' Technopreneurship Projects with Mobile Collaboration and Communication Application	PDF
<i>Stephanus Eko Wahyudi, Kartika Gianina Tileng, Ian Budi Kurniawan</i>	129-134
A Comparison of Real-Time Extraction between Chebyshev and Butterworth Method for SSVEP Brain Signals	PDF
<i>Dwi Esti Kusumandari, Taufik Hidayat, Arjon Turnip</i>	135-139
Comparative Analysis of Thresholding Methods in Cancer Cells Image Processing	PDF
<i>Daniel Martomanggolo Wonohadidjojo</i>	141-147
Cloud Computing Point of Sales Development for Indonesia Small Medium Enterprise	PDF
<i>Adi Suryaputra Paramita, Trianggoro Wiradinata</i>	149-152
Call for Paper Information Broadcast Based on Android Application	PDF
<i>Fenny Destasia Chan, Andreas Handojo, Hanny Tabita Listyani, Ivan Aldinata, Felicia Felicia</i>	153-158
Modeling of Energy Production of Sengguruh Hydropower Plant Using Neuro Fuzzy Network	PDF
<i>Daniel Rohi, Hanny H. Tumbelaka</i>	159-162
High Spatial Grid Resolution of Hydrodynamic Numerical Modeling for Sea Current Energy Site Selection in Indonesia	PDF
<i>S Hermawan, H Gunawan</i>	163-167
Brain Computer Interface for Controlling RC-Car Using Emotiv EPOC+	PDF
<i>Thomas Setiono, Andreas Handojo, Rolly Intan, Raymond Sutjiadi, Resmana Lim</i>	169-172
Forward and Inverse Kinematic of a Manipulator Simulator Software Using Unity Engine	PDF
<i>Handry Khoswanto, Kevin Nathanael Sugiharto, Iwan Njoto Sandjaja, Thiang Thiang</i>	173-176
Surabaya Tourism Destination Recommendation Using Fuzzy C-Means Algorithm	PDF
<i>Raymond Sutjiadi, Edwin Meinardi Trianto, Adriel Giovanni Budihardjo</i>	177-181
Saving Matrix Method for Efficient Distribution Route Based on Google Maps API	PDF
<i>Timothy John Pattiasina, Eddy Triswanto Setyoadi, David Wijayanto</i>	183-188
3D Platform Simulator Design Using Discrete Multi-Piston Actuators	PDF
<i>Roche Alimin, Felix Pasila</i>	189-192
Infants Cry Classification of Physiological State Using Cepstral and Prosodic Acoustic Features	PDF
<i>Ramon L. Rodriguez, Susan S. Caluya</i>	193-196



This work is licensed under a [Creative Commons Attribution 3.0 License](#).

ISSN: 2180-1843

eISSN: 2289-8131

Modeling of Energy Production of Sengguruh Hydropower Plant Using Neuro Fuzzy Network

Daniel Rohi and Hanny H. Tumbelaka

Electrical Engineering Department, Petra Christian University, Surabaya, Indonesia
rohi@petra.ac.id

Abstract—The hydroelectric power plant needs to be operated carefully to obtain optimal results, as it is highly dependent on water availability. Factors to take into account are the water discharge and the duration of time for the operation. Decomposition analysis method is the method chosen to manage the operation of hydropower. This paper discusses the hydropower operation model using artificial intelligence with Neuro Fuzzy Takagi-Sugeno (NFTS) network technique. The Hydropower plant selected for modeling is Sengguruh Hydroelectric Power Plant with a capacity of 29 MW. This model was developed using three factors as inputs. They are the discharge of water, turbine water discharge and duration of operation time. The output is electric energy production. The data used is the operating data for one year, from January to December. The model testing shows satisfactory results as it reveals the real conditions and the errors occurred on the network was below 6.7%.

Index Terms—Artificial Intelligence; Hydropower Plant; Neuro-fuzzy; Renewable Energy.

I. INTRODUCTION

Hydropower is the most dominant renewable energy generation in the world today. Hydropower contributes 16% of the total energy mix in the world. Worldwide hydroelectric growth increased significantly by 715 GW in 2004 to 1,018 GW in 2013 and 1,055 GW in 2014 or an increase of 32.22% over 10 years or an average growth of 3.22% /year.[1].

The development of electric energy in Indonesia faces several challenges, namely the disparity between the provider and the needs, the limitation of fossil energy, the dependence on fossil energy and environmental issues, and the demand for CO₂ emission reduction from the power generation sector [2][3].

Based on the development plan of electricity by the National Electricity Company Indonesia (2011-2020), electricity demand in Indonesia is growing by an average of 8.46%/ year. The power plant is the dominant fossil energy by 81%, consisting of coal by 64%. The capacity of power plants that exist today reaches a total of 34 928 MW [4].

The national electricity demand is 8.5%, while the growth of power plant development is 6.5% / year. Power plants are predicted to reach around 115 GW in 2025 and 430 GW by 2050. Electricity needs per capita, by 2013 764 kWh per capita increased threefold to 1,987 kWh per capita. In 2050 it is predicted to reach 6,112 kWh per capita [4].

Sengguruh Hydroelectric Power Plant is located at Sengguruh Dam, at Sengguruh village, Malang Regency, East Java Province. The dam began to operate in 1998. Sengguruh Dam is located at the upper reaches of the Brantas River. The total area of the Brantas River basin is 1659 km². The types of dams are concrete composites and rocks with

soil core. The dam body volume is 650,000 m³. The yearly electricity production target is 98.5 million kWh/year. This dam was built to keep the sediment from entering the Sutami dam.

The Hydroelectric Sengguruh is designed to bear the peak load for 5 hours every day. The main water discharge is 32.5 m³/sec. The effective waterfall height is 22.78 m and the type of turbine used is Kaplan turbine, with vertical shell type Kaplan reaction, and 15.1 MW energy output with 176.5 rpm rotation. The Turbines are operating at a maximum water height of 24.5m and a minimum water height of 18.5m. The generators used are two Synchronous AC Generators, 11KV, 16200 KVA / unit. The total installed capacity is 2x 14.5MW. The Technical characteristics of the dams and hydroelectric Sengguruh —is shown in Figure 1.

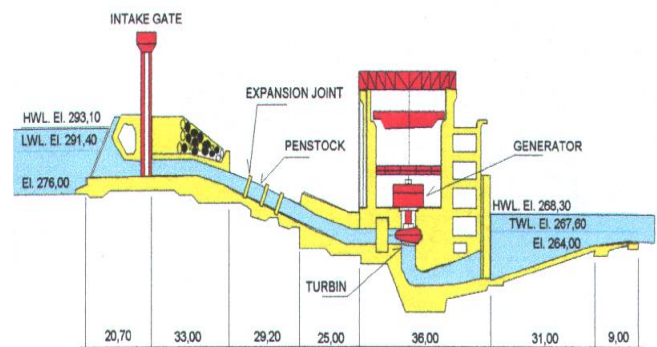

Figure 1: Profile of Sengguruh Hydroelectric Power Plant

The operation of the Sengguruh Hydroelectric Power Plant is facing a serious problem because the dam condition has been reduced up to 50% of the capacity. It is due to the amount of sediment coming in, exceeding the planned capacity [5]. The high sedimentation rate reaches 1,713,454,968 m³/year, this condition greatly affects the power production capability of the Sengguruh power plant. [6][7]

Hydroelectric energy production is influenced by two factors namely the availability of water and the capacity of the dam. The availability of water depends on rainfall whereas the capacity of the dam depends on the effective volume of the dam. The effective volume of the dam is shrinking due to the increasing amount of sediment buried in the dam. As a result, if the rainfall is high, the water contained in the dam is low, because the water will quickly overflow through the spillway of the dam.

In addition, the production of electrical energy from hydropower is also determined by the effective height and operation time. The effective height depends on the water

elevation at the dam. The Operation time–depends on the availability of water and hydropower equipment maintenance conditions, if the maintenance takes a long time, then the hydropower operation time becomes shorter.

The Factors affecting the production of electrical energy in Sengguruh Hydroelectric Power Plant can be studied by developing modeling. The modeling developed, will make it easier to control or manage those factors so as to obtain optimal electrical energy production conditions.

The data needs for modeling is the data directly related to the operation process. Those data are collected from daily recorded data on a regular basis

II. NEURO-FUZZY SYSTEM FOR MODELING OF PLTA SENGURUH

A neuro-fuzzy network with an improved training algorithm for Multi Input Single Output (MISO) case was developed by Palit and Popovic [8] and Pasila et.al [9-14]. They can be used for forecasting or modelling in time series, modelling material composite for artificial muscle and controlling discrete manipulator.

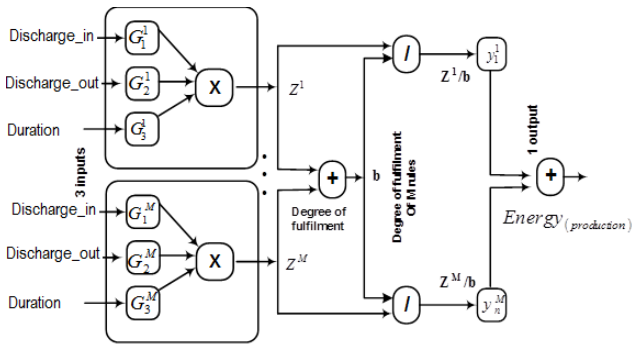

Figure 2: Sengguruh Hydropower Plant MIMO Model Using Feedforward Neuro-Fuzzy (NF) Network, Type Takagi-Sugeno with Training Method: Levenberg-Marquardt Algorithm (LMA)

The proposed model of NF network as shown in Figure 2 is based on Gaussian. It uses Takagi Sugeno rules, product inference, and weighted average defuzzification. The first nodes compute the degree of membership of the input values (debit input, debit output and duration) in the antecedent sets. The product nodes (x) denote the antecedent conjunction operator and the output of this node is the corresponding to the degree of fulfillment of the rule. The division (/), together with summation nodes (+), join to make the normalized degree of fulfillment (z^l/b) of the corresponding rules, which after multiplication with the corresponding TS rule consequent (y_j^l), is used as input to the last summation part (+) at the defuzzified output value, which, being crisp, is directly compatible with the next output data (energy production).

Neuro-fuzzy representation of the FS is based on the inference TS-type which has been explained clearly by Palit [8]. There are two important steps in this representation: calculating the degree of fulfillment and normalized degree of fulfillment. The FS considered here for constructing neuro-fuzzy structures is based on TS-type fuzzy model with Gaussian membership functions. It uses product inference rules and a weighted average defuzzifier.

The corresponding rule from the above FS can be written as:

$$R_l = \text{If } x_1 \text{ is } G_1^l \text{ and } x_2 \text{ is } G_2^l \text{ and } \dots x_m \text{ is } G_m^l \text{ then } y_j^l = W_{0j}^l + W_{1j}^l x_1 + \dots + W_{mj}^l x_m \quad (1)$$

where, “and” are the m system inputs and “n” system outputs, “and” are the Gaussian membership functions of the form (1) with the corresponding mean and variance parameters and respectively “and with” as the output consequent of the rule.

Moreover, FS is represented as a three-layer MIMO feedforward network as shown in Figure. 1 Due to the implementation of the Takagi-Sugeno-type FS, this figure represents a Takagi-Sugeno-type of MIMO neuro-fuzzy network, instead of the connection weights and the biases in training algorithm. We introduce the mean and the variance parameters of Gaussian functions, along with parameters from the rules consequences, as the equivalent adjustable parameters of TS-type network. If all parameters for NF network are properly selected, then the FS can correctly approximate any nonlinear system based on given related data between four inputs and four outputs.

$$F_j = \sum_{i=1}^M y_j^i \cdot H^i \quad (2)$$

$$H^i = \left(z^i / \sum_{l=1}^M Z^l \right), \quad Z^l = \prod_{i=1}^m \exp \left(- \left(\frac{x_i - c_i^l}{\sigma_i^l} \right)^2 \right) \quad (3)$$

$$y_j^l = W_{0j}^l + W_{1j}^l x_1 + W_{2j}^l x_2 + \dots + W_{mj}^l x_m \quad (4)$$

Prior to their use, NFTS and NFLUT models require the tuning of the parameters c_j^n , σ_j^n , w_{0i}^n , w_{ji}^n (for $j = 1, 2, 3$; $i = 1$);). Here, the number of parameters depends on n (membership functions), j (input) and i (output). If n, j and i are set to the values of 7, 3 and 1 respectively then we have a total of 70 parameters. The optimized values of these parameters are found by an optimized learning procedure. The learning procedure employs all data (100%) of the input-output XIO correspondences from the known dataset.

III. RESULTS AND DISCUSSION

The model of the Sengguruh Hydroelectric Power Plant was built using historical data for one year. The data was taken from the daily data for one year or 365 days. The data was from 1 January 2012 up to 31 December 2012. They were recorded and reported data used as the operational report of HEPP Sengguruh. This modeling used the data of 2012.

The Data of water discharge entering the dam is recorded every day. The data changes depending on the rainfall conditions that occur around the dam. The water discharge conditions change following the changing season. Indonesia is located — at the tropics. So it has only two seasons, rainy and dry seasons. Dry season occurs in April to September and the rainy season occurs during October up to March.

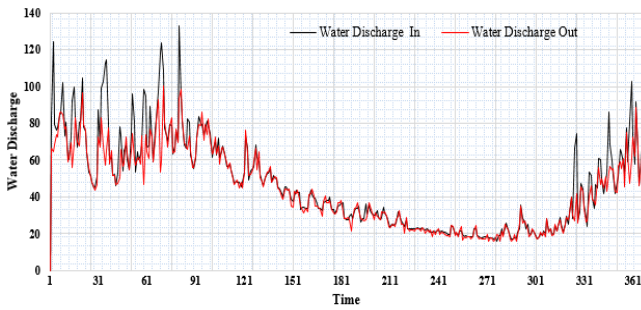

Figure 3: Comparison between Incoming Water Discharge and Outflow Water Discharge of Sengguruh Hydroelectric Power Plant

The pattern of water discharge data coming into the dam and discharge of water coming out of the dam or that is used to drive the hydro turbine is shown in Figure 3.

The average water discharge coming in 2012 was 46.96 m³/sec. The highest discharge was 132.71 m³/sec and the lowest was 16.18 m³/sec. The highest occurred in March and the lowest in July 2012. The average water discharge coming out in 2012 was 43.92 m³/sec. The highest discharge was 100.17 m³/sec and the lowest was 15.93 m³/sec. The highest occurred in March 2012 and the lowest in July 2012.

The data shows that the discharge of water used for turbine was smaller compared to the incoming water discharge. This condition is to keep the water in the dam in a stable elevation, to obtain maximum effective height.

The hours of operation from Sengguruh Hydroelectric Power Plant follow the conditions of water availability. Figure 4 shows that there is a similar pattern between the discharge water to drive the turbine with the operating-time. As the amount of water discharge increases, the operating time is also seen to be increasing.

The duration of operating time of the Sengguruh Hydroelectric Power Plant in 2012 was 22.26 hours on average. The highest duration time was 46.67 hours and the lowest was 9.55 hours. The highest duration of operating time occurred during the rainy season and the lowest occurred during the dry season.

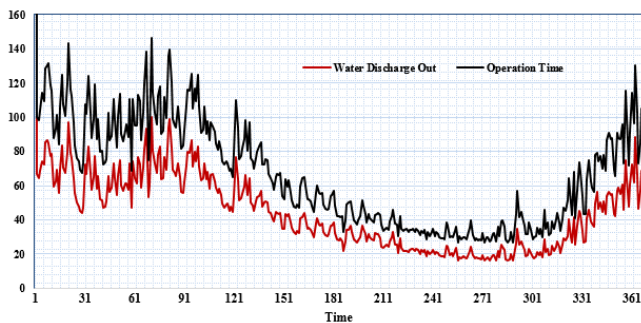

Figure 4: Comparison between Water Discharge Outflow and Operation Time of Sengguruh Hydroelectric Power Plant

Energy production is the output of hydropower operations. The average production of Hydroelectric Energy Sengguruh is 222,783 kWh per year, with the maximum of 513,800 kWh and the minimum of 75,100 kWh. The Energy production has a correlation with the water discharge and operating time.

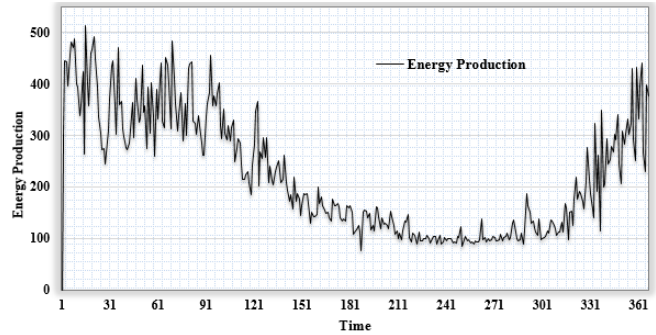

Figure 5: Total Annual Energy Production of Sengguruh Hydroelectric Power Plant

Maximum production occurs at the time of maximum water discharge and maximum hours of operation. This condition occurs during the rainy season. While the production is decreasing following the decrease of water discharge entering the dam. The pattern of production of electrical energy is shown in Figure 5.

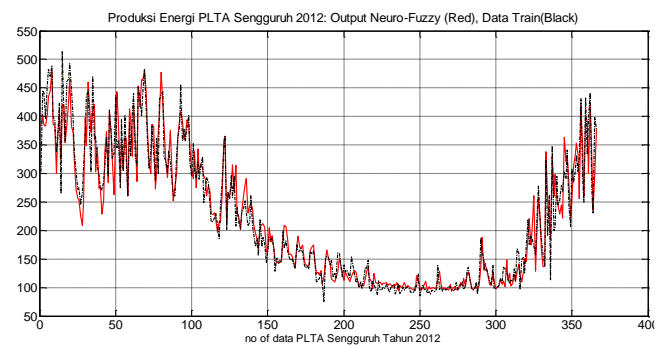

Figure 6: PLTA Sengguruh Plant Result Using Feedforward Neuro-Fuzzy (NF) Network

Figure 6 shows the comparison of the results obtained by NFTS network. In this regards, the results achieved by the NF method is taken as the baseline. The performance of NFTS network is quite satisfactory. The error generated in the network is 6.7 %, which is quite low and acceptable.

IV. CONCLUSION

This paper presents the implementation of Artificial Intelligence (AI) tool based —on the model of PLTA Sengguruh energy production in Indonesia. The model of AI is using Neuro-Fuzzy with three Inputs and one Output. It proves that the model can perform well and the results obtained in term of errors is very promising. The AI model using feedforward Neuro-Fuzzy (NF) Network proved to be effective to model Sengguruh Hydroelectric Power Plant with satisfactory results. The level of accuracy reached 92.3%. The Modeling has been tested to determine the operation pattern of the reservoir, so that the electrical energy produced reaches the optimum condition. This modeling is tested by considering the discharge of water entering the dam, the water discharge to move the turbine and the correct amount of operation time based on the condition. Further research should be conducted for developmental action. More data is needed to generate a more accurate level of accuracy.

ACKNOWLEDGMENT

Acknowledgments are dedicated to the Director General of Higher Education, Ministry of Research, Technology and Higher Education of the Republic of Indonesia who has provided funding assistance through the research schemes of Applicable Product Research Grants of Higher Education in 2017.

REFERENCES

- [1] Adib, Rana, et al. "Renewables 2016 Global Status Report." Global Status Report Renewable Energy Policy Network for the 21st Century (REN21) (2016): 272.
- [2] Bartle, Alison. "Hydropower potential and development activities." Energy Policy 30.14 (2002): 1231-1239.
- [3] Rohi, Daniel, M. Bisri, and A. Lomi. "Dynamic System Models Sutami Hydropower Plant Indonesia to Calculate the Economic and Environmental Aspects of Hydropower Plant Operation." *Applied Mechanics and Materials*. Vol. 815. Trans Tech Publications, 2015.
- [4] ESDM Indonesia (2008), Handbook of Economic Energy Statistic in Indonesia 2006 <http://www1.esdm.go.id/files/publikasi/buku/2006>
- [5] Limantara, Lily Montarjih. "Optimization of Water Needs at Kepanjen Dam and Sengguruh Dam, East Java, Indonesia." *International Journal of Academic Research* 2.5 (2010).
- [6] Sukatja, Bambang. "The Problems of Small Reservoir That Built In River Basins with High Sedimentation Rate, a Case Study of Sengguruh Reservoir." *International Journal of Academic Research* 3.4 (2011).
- [7] Fidari, Jafan Sidqi, Mohammad Bisri, and Ery Suhartanto. "Study of residual age estimation for sutami reservoir with sedimentation approach." *Journal of Water Engineering* 4.2 (2014).
- [8] Palit A. K., Popovic D. "Computational Intelligence in Time Series Forecasting, Theory and Engineering Applications". Springer (2005)
- [9] Pasila, F., Alimin, R." Applications of artificial intelligence control for Parallel Discrete-Manipulators". 4th IGNITE Conference and 2016 International Conference on Advanced Informatics: Concepts, Theory and Application, ICAICTA (2016)
- [10] Alimin, R., Pasila, F." Design of Two-Serial Hexapod of Discrete Manipulator". Proceedings of International Conference on Computational Intelligence, Modelling and Simulation 2016-September, 7579697, pp. 69-73 (2016)
- [11] Pasila, F., Alimin, R. "Coordinates modelling of the discrete hexapod manipulator via artificial intelligence". *Lecture Notes in Electrical Engineering* 365, pp. 47-53 (2016)
- [12] Pasila, F., Ronni, S., Thiang, Wijaya, L.H. "Long-term forecasting in financial stock market using accelerated LMA on neuro-fuzzy structure and additional fuzzy C-means clustering for optimizing the GMFs". Proceedings of the International Joint Conference on Neural Networks 4634367, pp. 3961-3966 (2008)
- [13] Pasila, F., Alimin, R., Natalius, H. "Neuro-fuzzy architecture of the 3D model of massive parallel actuators". *ARNP Journal of Engineering and Applied Sciences* 9(12), pp. 2900-2905 (2014)
- [14] Whulanza, Y., Hadiputra, A.P., Pasila, F., Supriadi, S. "Electromechanical characterization of bucky gel actuator based on polymer composite PCL-PU-CNT for artificial muscle". *Lecture Notes in Electrical Engineering* 365, pp. 185-192 (2016).