

Performance of Mechanical Energy Harvesting Unit for Generating Electricity for Portal Gate System

Joni Dewanto¹, Oegik Soegihardjo²

^{1,2}Mechanical Engineering Department, Faculty of Industrial Technology, Petra Christian University

Jl. Siwalankerto 121-131, Surabaya 60236. Indonesia

Phone: 0062-31-8439040, Fax: 0062-31-8417658

Email: jdewanto@petra.ac.id¹, oegiks@petra.ac.id²

Abstract--- The portal gate systems for parking area need electricity for opening/closing the portal (barrier crossbar) and printing the parking ticket. The mechanical energy harvesting unit presented on this paper is designed for supplying electrical energy needed by the portal gate system for its operation. The mechanical energy harvesting unit converted linear movement of the slider into rotating movement of the fly wheel using rack and pinion. The energy stored in the fly wheel is used to turn a small electric generator attached to the energy harvesting unit that provided electricity for the portal gate system. This energy harvesting unit is designed as a breakthrough to produce electrical energy by utilizing the weight of the vehicle that enters the parking space.

The linear movement of the slider is gained from the weight of the vehicle that passed on the mechanical energy harvesting unit. This system is appropriate for a stand alone portal gate systems. Three categories of passanger cars (small, medium and large) each with mass of 1300 kg, 1700 kg and 2000 kg respectively were used in the experiment. Considering the mechanical efficiency of the harvesting unit by 60%, three vehicles used were able to produce a maximum rotation of the electric generator of the harvesting units for 2585 rpm, 2964 rpm and 3210 rpm, respectively. Testing of the harvesting unit generator with a continuous rotation with an electrical load taken from LED lights with voltage of 24 Volt, 18 Volt and 12 Volt produces power of 19 Volt x 3.6 mAmp (4000 rpm), 17 Volt x 4.3 mAmp (3500 rpm) and 12 Volt x 11 mAmp (2400 rpm) respectively. Initial testing of the mechanical energy harvesting unit shows that this equipment is capable of producing the required electrical energy.

Key words: mechanical energy harvesting unit (MEHU), fly wheel, generator performance, electrical load.

I. INTRODUCTION

The use of car or vehicle weights to drive a generator driving mechanism that is capable of producing electrical energy is an alternative way for supplying electrical energy [1], [2]. In the midst of fossil fuel and energy crisis, obtaining a new sustainable source of energy to power portable devices become a new field of research for renewable energy harvesting. Mechanical system as sources of energy can be an interesting alternative to harvest energy [3].

Compared to the way of generating electricity by using a diesel engine, the use of

car or vehicle weights to drive a generator driving mechanism is more environmentally friendly because it can eliminates the exhaust gas pollution and also reduces the use of fossil fuel. When mechanical energy is available either from vehicles, human and other vibrating structures, the mechanical energy harvesting remains an option that can be considered [4].

In terms of the amount of electrical energy produced, diesel engine driving electric generator is indeed capable of producing quite large electrical energy compare with that of vehicle weight driving electric generator. But

for small scale electrical energy sources the design of energy harvesting unit utilizing various sources of mechanical drive are increasingly being used. Improving the conversion of the mechanical energy into electrical energy still become an interesting field of research on renewable energy [5].

The use of flywheels as energy storage is widely used because their ability to store energy can be used for various things [6]. The development and improvement of flywheel design in the automotive field is able to save fuel up to 20% for buses and up to 35% for regular cars [7]. Even for small scale mechanical harvesting unit, the proper design of the flywheel still have to be considered.

To be able to make the most of the energy from the flywheel, the design and selection of the flywheel dimensions must be done carefully to prevent the negative effects of flywheel design inaccuracies [1], [7]. Improper

design of the flywheel can harm the mechanism if its angular speed is exceeded [8].

II. THEORETICAL BACKGROUND

The mechanical energy harvesting unit (MEHU) presented in this paper uses a rack and pinion mechanism to convert translational movements into rotational movements. The mechanical part of the harvesting unit is shown in Fig. 1. The dimensions and rotational (angular) speed of the flywheel in the mechanical system of the MEHU are designed based on the safety criteria as explained by designer to ensure its safe operation [7], [8].

The entire MEHU unit consists of mechanical unit and electrical units as shown in Fig. 2. When the vehicle passes at MEHU the vehicle's wheel will press the slider connected to the rack downward as shown in Fig.1.

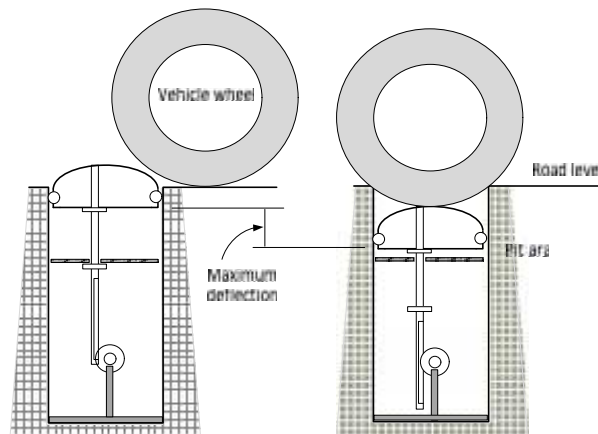

Fig. 1 Mechanical system of the MEHU.

The rack will rotate the pinion mounted on the same shaft with the flywheel. When the vehicle's wheels pass the MEHU slider, the slider will displace downward for 12 cm (0.12 m). Assuming the weight of the vehicle is evenly distributed at the front and rear wheels, the amount of energy from the weight of the

vehicle at the front wheels is calculated by equation (1).

$$U = \frac{W}{2} s \quad (1)$$

W is the weight of the vehicle, (N) and s is slider displacement, (m).

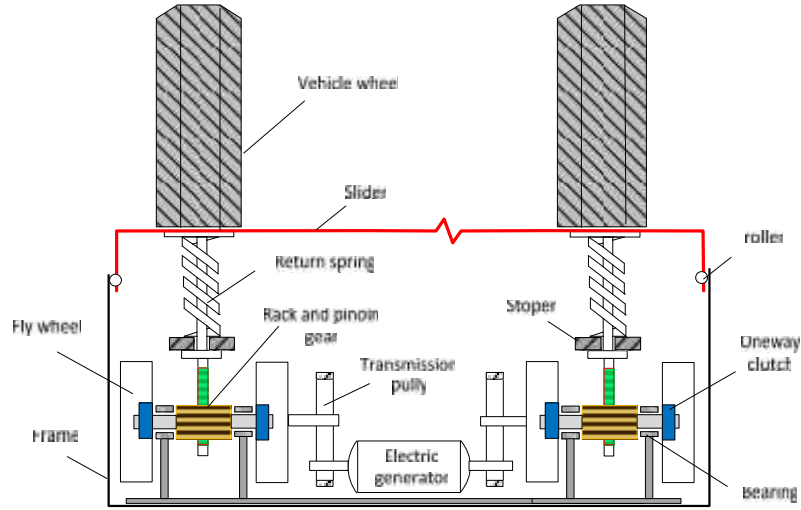

Fig. 2 Mechanical energy harvesting unit (MEHU).

From the energy conservation law, the amount of energy received and the rotational speed of the flywheel can be calculated by equation (2).

$$U = 0.5 I \omega^2$$

$$I = 0.5 m R^2$$

$$\omega^2 = \frac{2U}{I} \quad (2)$$

I is mass moment of inertia of the flywheel, R radius of flywheel (m), ω angular velocity of flywheel, (rad/sec). The ratio of the pulley diameter on the flywheel shaft to the pulley diameter on the generator shaft as shown in Fig. 2 is 4 to 1.

III. RESULTS AND DISCUSSION

This section discusses the results of the testing of the mechanical energy harvesting units (MEHU). The testing of the unit consists of two parts. The first testing is to measure the ability of the mechanical system of MEHU. This test is carried out to get the maximum rotation that the generator can get when the

vehicle passes the MEHU. The second testing is to measure the ability of the generator to produce voltage and electric current under various loads and rotations. To facilitate the measurement of the generator performance, the testing of the electric generator of the MEHU is carried out at a constant rotation or constant speed.

A. Results of the MEHU Mechanical System Testing

Table 1 shows the mechanical system performance of the MEHU which was tested using three vehicle weight, categorized as small, medium and large vehicle. The efficiency of the mechanical system from MEHU is assumed for 60%. The generator speed (rotation) in Table 1 is the maximum speed that the generator can reach when the vehicle passes the MEHU. After the vehicle passes the MEHU, the generator rotation will decrease until finally it stops. The maximum speed of the generator is obtained based on pulley diameter ratio of 4 to 1 as shown in Fig. 2

TABLE 1.
PERFORMANCE OF MEHU MECHANICAL SYSTEM.

No.	Mass of vehicle (kg)	Weight of vehicle (N)	Generator rotation (rpm)
1	Small (1300 kg)	12,740	2585
2	Medium (1700 kg)	16,660	2964
3	Large (2000 kg)	19,600	3210

Table 1 shows the result of testing that represents the ability of the MEHU mechanical system to rotate the electric generator. The MEHU mechanical system is able to produce rotational movements from 2585 rpm to 3210 rpm. This rotation range corresponds to the rotation range required by the MEHU electric generator.

B. Results of the MEHU Electric Generator Testing

MEHU electric generator testing is carried out at constant speed (constant rotation) with various electric loads using LED lamps. Testing of electric generators at constant rotation is carried out to facilitate an easy measurement. When testing the electric

generator at changes speed (based on the transient movement of the slider mechanism of the MEHU), the voltage and current measuring devices cannot read the data properly. Characteristics of measuring instruments used in this experiment (volts and amperes meters) can only read data properly when condition or generator speed is steady

The ability or performance of the MEHU electric generator is expressed in term of voltage and current curves in the following figures. The electrical load is obtained or taken from LED lights consisting of 8, 6 and 4 lamps arranged in series to produce a voltage of 24, 18 and 12 volts respectively, to match the voltages generated by the electric generator.

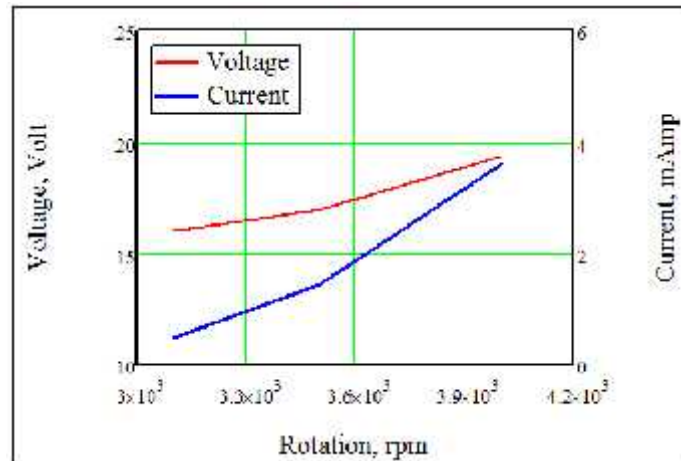

Fig. 3 Voltage and Current taken from load of 8 LED lamps at various generator rotation (rpm).

Fig. 3 is the performance of the electric generator with a load of 8 LED lamps (24 volts). Rotation range starts from 3100 rpm, 3500 rpm to 4000 rpm, the resulting voltages

start from 16 volts, 17 volts to 19.4 volts, with the resulting currents are 0.48 mA, 1.43 mA to 3.6 mA respectively.

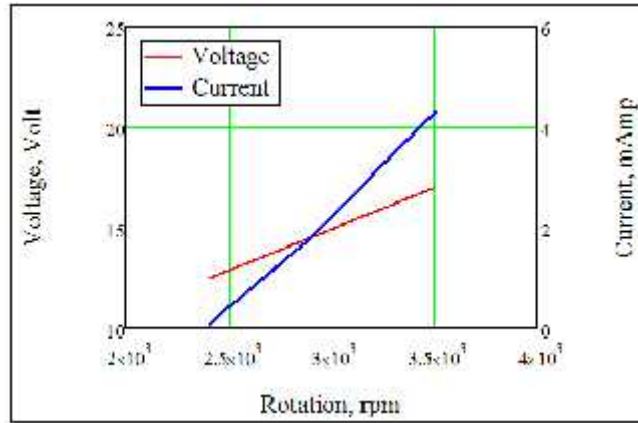

Fig. 4 Voltage and Current taken from load of 6 LED lamps at various generator rotation (rpm).

Fig. 4 is the performance of the electric generator with a load of 6 LED lamps (18 volts). The rotation range starts from 2400 rpm, 2900 rpm to 3500 rpm; the resulting voltages

start from 12.5 volts, 14.5 volts to 17 volts, with the resulting currents are 0.1 mAmp, 1.8 mAmp to 4.3 mAmp respectively.

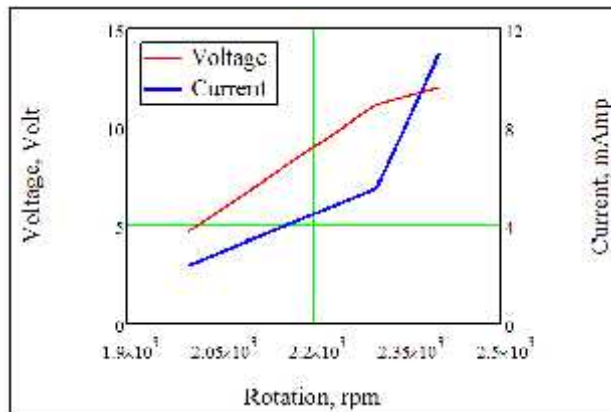

Fig. 5 Voltage and Current taken from load of 4 LED lamps at various generator rotation (rpm).

Fig. 5 is the performance of the electric generator with a load of 4 LED lamps (12 volts). The rotation range starts from 2000 rpm, 2300 rpm to 2400 rpm; the resulting

voltages start from 4.7 volts, 11.2 volts to 12 volts, with the resulting currents are 2.4 mAmp, 5.5 mAmp to 11 mAmp respectively.

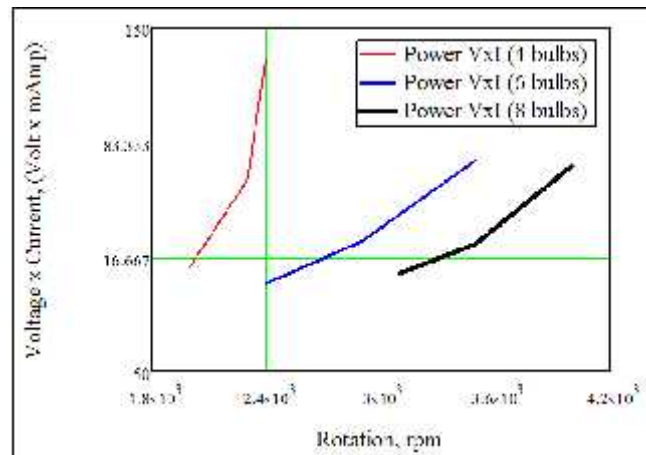

Fig. 6 Electric power taken from load of 8, 6 and 4 LED lamps at various generator rotation (rpm).

Fig. 6 shows the power curve that can be produced by the electric generator as a function of generator rotation, according to the load taken from several LED lamps being tested, namely 12 volts, 18 volts and 24 volts. To store the electric power generated by the electric generator either a 12 volts battery or a 24 volts battery can be chosen. Based on the generator performance curves shown in Fig. 3 to Fig. 6 show that the mechanical system of the MEHU is able to rotate the electric generator to produce voltages and electric currents.

C. Constraints During the Experiments

Some obstacles arise during the experiments. The first obstacle is the onset of friction between slider and vertical frame of the MEHU mechanical system when the slider moves downward. When the car passes the MEHU, the slider cannot directly move down but swipe the MEHU vertical frame. This impedes the linear motion of the slider and reduces the maximum rotation generated by the MEHU mechanical system. This first obstacle can be overcome by adding rollers on the slider side. The roller added on the side of the slider can reduce significantly the friction between slider and vertical frame of the MEHU and at the time it will improve the linear motion of the mechanical system.

The second obstacle is the inability of the measuring devices to read data (voltage and

current) when the generator speed or rotation is changes (transient rotation), so the voltage and current data can not be captured. During testing the electric generator using changing or transient rotation, the LED light (as an electric load) turns on when the generator rotates at maximum rotation until a few moments before the rotation stops. This shows that the MEHU is able to produce electrical energy in transient rotation. But how much the voltages and currents generated, they can not be read by a measuring devices. The voltage and current measuring devices that capable of reading transient loads are needed to read data.

D. Further experiments

Further experiments must be carried out to explore the capability of the MEHU when operated under different operating condition. The first experiment will be conducted is to test the ability of MEHU to produce electric power while the electric generator is operated under changing speed (transient rotation). The following experiment is to determine how many cars per hour that must pass through MEHU to produce economical and sufficient electric power to be stored in batteries.

IV. CONCLUSIONS

The designed of the mechanical energy harvesting unit (MEHU) is capable of producing rotation accordingly to produce sufficient electrical energy by utilizing the weight of the vehicle. Thus the MEHU can be

used as an alternative way to produce small-scale electrical energy.

The weight of various vehicles parked in the urban parking areas with mass of 1300 kg, 1700 kg and 2000 kg, respectively, are capable of producing a maximum MEHU rotation of 2585 rpm, 2964 rpm and 3210 rpm. Thus the use of vehicle weights as a driving source of the MEHU to supply the electricity needs by the portal gate system is appropriate.

The MEHU testing with constant speed using various loads of LED lamps with 24 Volt, 18 Volt and 12 Volt voltage produces power of 19 Volt x 3.6 mAmp (4000 rpm), 17 Volt x 4.3 mAmp (3500 rpm) and 12 Volt x 11 mAmp (2400 rpm) respectively.

V. ACKNOWLEDGEMENTS

The research is supported and funded by Research Grant (Penelitian Dasar Unggulan Perguruan Tinggi) from the Ministry of Research and Technology of Higher Education of Indonesia during the 2019 fiscal year.

The authors also would like to thank the Manufacturing Laboratory of Mechanical Engineering Department of Petra Christian University which provides facilities and supporting equipments needed for this research.

VI. REFERENCES

- [1] L. Wang, J. Park, W. Zhou, J. Ban, and L. Zuo., On-Road Energy Harvesting for Traffic Monitoring., Final Report., University Transportation Research Center-Region II, City College of New York, Nov. 2014
- [2] Y. Chen, H. Zhang, C. Li, H. Zheng, and Q. Yang, Mechanical Energy Harvesting from Road Pavement Under Vehicular Load Using Embedded Piezoelectric Elements., *Journal of Applied Mechanics*, Vol. 83, 2016
- [3] I. Sil, S. Mukherjee, and K. Biswas, A Review of Energy Harvesting Technology and Its Potential Applications., *Environmental and Earth Sciences Research Journal*, A Publication of IIETA, Vol. 4, No. 2, June 2017, pp. 33-38.
- [4] P.C.K. Devi, Survey on Energy Harvesting Techniques., *International Journal of Computer Science Engineering and Technology (IJCSSET)*, Vol. 4, Issue 10, p 256-259, Oct. 2014.
- [5] R.L. Harne and K.W. Wang, A Review of the Recent Research on Vibration Energy Harvesting via Bistable Systems., *IOP Publishing Ltd., Journal of Smart Materials and Structures*, **22**, 12pp (2013).
- [6] L.T.E. Nyamayoka, G.A. Adewumi and F.L. Inambao., Design of a Prototype Generator Based On Piezoelectric Power Generation for Vibration Energy Harvesting., *Journal of Energy in Southern Africa*, **28**, Number 4., p. 32-40, 2017.
- [7] M. Hedlund, J. Lundin, J. Santiago, J. Abrahamsson, and H. Bernhoff, Flywheel Energy Storage for Automotive Applications., *Energies* 2015, Open Access Journal, p 10636-10663.
- [8] (2008) Active Power Inc., Understanding Flywheel Energy Storage: Does High.Speed Really Imply a Better Design., White Paper 112, Austin, Texas, www.activepower.com