

Dimensional Optimization of Clutch disc with Simulation of Stress Analysis (Study Cases : Clutch Disc Hino FM 260Ti)

Ninuk Jonoadji¹, Sutrisno¹, Ian Hardianto Siahaan¹, Melvin Emil Simanjuntak²,
Melvin Bismark Hamonangan Sitorus², Michael Suryajaya³

1 Mechanical Engineering Department, Petra Christian University
Jln. Siwalankerto 121-131, Surabaya, East Java, Indonesia.

Email : tengsutrisno@petra.ac.id.

2 Mechanical Engineering Department, State Polytechnic of Medan
Jln Almamater No.1, Padang Bulan, Medan, North Sumatra, Indonesia.

3 Mechanical-Aerospace-Automotive Engineering Department, Coventry University.
Priory Street, Coventry United Kingdom, CV1 5FB, United Kingdom

Abstract. The function of clutch disc is to transmit the power from the engine to the transmission. There are a lot of vehicle that equipped with different size of engine capacity. Therefore, it is required to use a clutch disc with the appropriate capability to transmit the power from the engine. Note that there is a clutch disc modification type that combine the Japanese and European design called clutch disc Hino MB. This type clutch disc is used for Hino FM 260Ti. By using the combination design, the clutch disc will have longer lifetime and lower risk to crack. There is a crack problem that happened from the usage of clutch disc Hino MB. Therefore, it is necessary to do a research to optimize the design of clutch disc Hino MB. This research is done by making several new designs of clutch disc Hino MB and tests it through simulation of stress analysis. The parameter that had been analysed is the value of von mises stress from each design. The length of grooves is also analysed to get a better design result. This research produces a new design of clutch disc Hino MB that has better design structure. The best result of the simulation that has been done to the clutch disc with interval 5 mm reduction is owned by clutch disc with 35 mm groove's length reduction and the value is 121.1 MPa.

Keywords: Clutch disc, von Mises stress, stress analysis, Truck.

1. Introduction

Clutch disc is one of the important part in vehicle transmission system. It has a function to engage and disengage the power that transmitted from the engine. The friction surface of the clutch disc will have a contact with flywheel and pressure plate from clutch cover. Clutch disc design combination between Japanese design and European design is already exist. The design combination has an aim to get a clutch disc that can be used by HINO trucks with a better quality, longer lifetime, more comfortable usage, and lower purchase price. Nevertheless, there is a problem in a HINO MB clutch structure. It can be noticed that there is a crack that happened on clutch disc HINO MB after being used at a certain period. Getting a new optimum clutch disc design is expected to solve the problem through this experiment.

There is a reference that has a title Static and Dynamic Analysis of Clutch Plate with Crack (1) reviewing about crack or failure that happen on clutch disc. From that reference, the cause of the problem can be discovered and could be used as a base to design a clutch disc. Design and Structural Analysis of Single Plate Friction Clutch (2) explain several factors that have to be considered in designing clutch disc. This reference also explain how big is the maximum stress that can be received or transmitted by the clutch disc, structure analysis, and material strength of clutch disc. Designing a clutch disc with combined pattern has to consider several factors so that the outcome could be more perfect. The clutch disc development is still very good in the future. Some research has shown that there are still so many aspects in clutch system that could be developed. One of them can be developed is making a clutch disc that has higher performance with lower price. This factor has been investigated by The Clutch System of The Future (3).

Optimization design that is done to clutch disc, aim to find a better design and has a better quality. The research about optimization design. Research about parts of clutch disc is done with analysed how does each part work so clutch work could be more optimum. The research that analysed about parts of clutch disc is written in Design and Finite Element of Clutch Disc (4).

Improve optimization of clutch disc HINO MB could be done with redesigning the structure of the clutch disc HINO MB to get better structure design and the problem that exist could be minimize. Therefore, the design of the clutch disc is needed to be improved.

2. Research Method

Clutch disc HINO MB has a combination design between HINO design and Mercedes design. Therefore, combining the design between those two types of clutch disc has to be done first. HINO MB has ever existed before so the clutch disc or the part of the previous model is used for measurement purpose. This type of clutch disc is shown by figure 1a.

After that, clutch disc HINO MB has to be drawn using CAD in original size. This is shown by Figure 1b. Furthermore, it is required to do the simulation in order to discover the performance of the clutch disc. The result of the simulation would be used as a reference to compare with the new design that would be made. The result also has to be analysed whether it is pass or fail. If the simulation result shows that clutch disc HINO MB with original model is fail, then the current model is required to be modified. It can be noted that the new design of clutch must fulfil the performance requirement. The performance can be observed by executing finite element simulation. It can be noted that the length characteristic of the clutch plate grooves is used as one of the design variable in order to obtain a better design. This analysis is done because the factor of groove's length is the most optimum factor that can be modify.

The first method is executed by reducing the groove's length with 5 mm interval. The reduction is started from 20 mm until 45 mm every 5 mm. In order to get the result accurately, the second method is performed by reducing groove's length with 1 mm interval. Note that once the results of the simulation are obtained, it is required to carry out the analysis in order to find out the characteristic of changing the design variables.

Apart from the groove's length (P), there are several additional design variables need to be used in the analysis which are slope angle of the grooves (α), number of the grooves (Z), the width of the grooves (L), and the radius of the grooves (R). The aim is to determine which variable that has the biggest impact on the performance of the clutch disc. Indeed, it is very important to define the best variable in order to develop the performance of the clutch disc. All parameters of dimensional design and detail dimensional is shown by figure 2 and table 1.



a).

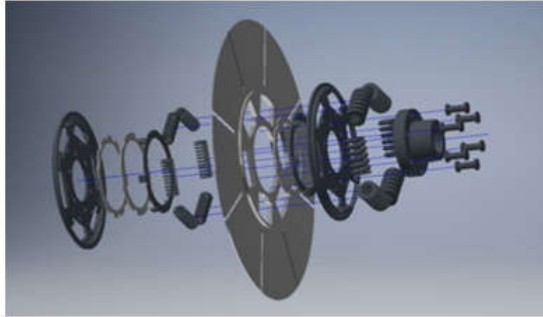

b).

Figure 1 Clutch HINO MB SEA, a) Photo, b) CAD

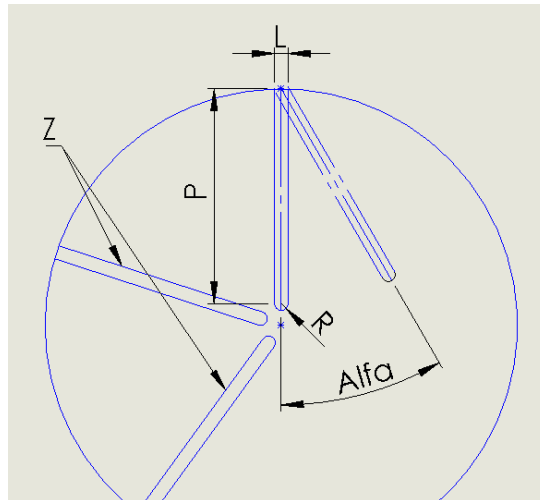

Figure 2 Parameter of Design concept

It can be noticed that the first design model is made by reducing the length of groove by 45 mm. The groove of design model 2 is modified by reducing the length by 45 mm and dilated 5 mm. Clutch disc of design model 3 is carried out by reducing the groove's length by 20 mm. Next, the groove is modified into only 6 units for design model 4 which originally was 8 units. The groove's length in design model 5 is constructed by combining the original groove's length and the groove's length with 45 mm reduction alternately. Furthermore, it is possible to see that modifying the angle of the groove is executed for design model 6 and 7. Note that 7.5 and 5 degrees are chosen as the size of the angle for design model 6 and 7 respectively. All of the 7 design models can be seen by on figure 3.

Table 1 Parameter Design Concept

| Design | P (mm) | α (degree) | Z (number) | L (mm) | R (mm) |
|--------|-------------|----------------------|---------------|-----------|-----------|
| 1 | 42.86 | 0 | 8 | 4.9 | 2.45 |
| 2 | 42.86 | 0 | 8 | 9.9 | 4.95 |
| 3 | 67.86 | 0 | 8 | 4.9 | 2.45 |
| 4 | 87.86 | 0 | 6 | 4.9 | 2.45 |
| 5 | 87.86/47.86 | 0 | 8 | 4.9 | 2.45 |
| 6 | 83.55 | 7.5 | 8 | 5 | 2.5 |
| 7 | 84.62 | 5 | 8 | 5 | 2.5 |

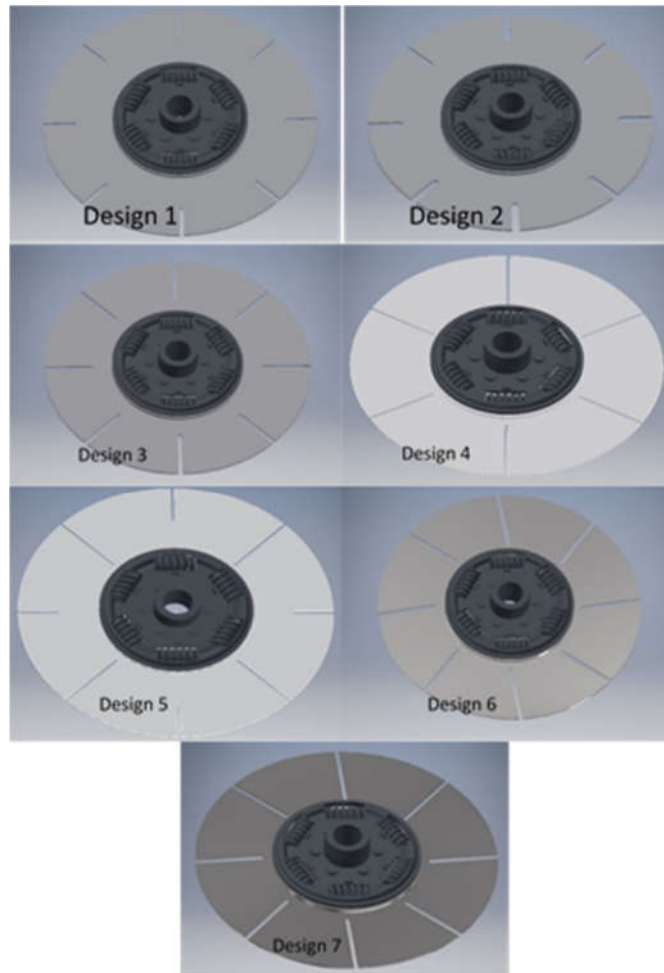

Figure 3 Design concept

Simulation method of finite element analysis (FEA) is executed. Before performing the simulation, there are several parameters that required to be determined based on the condition during the engagement of the clutch disc. It is very important to do this step so that the result can represent the real condition of the clutch system. FEA is often done by previous researchers, one of which is Efendi and Andoko (5) the occurrence of cracks on a four-cylinder crankshaft. In addition, Nanang and Femiana G (6) have applied FEA for the development of tires against rolling resistance and noise estimation. FEA is very relevant to be used in developing clutch disk products like this research.

Therefore, the calculation process is needed to be done. The value of pressure force or normal force produced by the clutch cover that suppress the clutch disc's frictional area (clutch facing) during the clutch engagement can be calculated using the following formula:

$$F = \frac{\pi}{4} \cdot (D_2^2 - D_1^2) \cdot Pa \quad (1)$$

Where D2 is outer diameter of the frictional area of the clutch (381 mm), D1 is inner diameter of the frictional area of the clutch (266.7 mm), and Pa is average pressure that needed by the friction material in order to engage with the pressure plate. Furthermore, the formula of maximum torque that supposed to be transmitted by the clutch can be seen on:

$$T = \mu \cdot n \cdot F \cdot \left(\frac{R_2 + R_1}{2}\right) \quad (2)$$

Where μ is friction coefficient, n is the number of clutch facing attached on the clutch plate. The value of the maximum torque that can be transmitted by the clutch is 1,316 Nm. It is required to input this value into the simulation.

The friction coefficient that chosen for the simulation is representing the contact of asbestos on steel or cast iron. Friction coefficient values based on contact between two different materials in Friction Material of Clutches by Joseph E S and Charles R M (7). The next step is done by meshing with parameter average element size 0.1, minimum element size 0.2, grading factor 2.1 and maximum turn angle 60°. Furthermore, the FEA software will be processing the simulation based on the calculation of von Mises stress which has a base formula 3:

$$\sigma_{vm} = \left[\frac{1}{2} \{ (\sigma_x - \sigma_y)^2 + (\sigma_y - \sigma_z)^2 + (\sigma_z - \sigma_x)^2 \} + 3(\tau_{xy}^2 + \tau_{yz}^2 + \tau_{zx}^2) \right]^{1/2} \quad (3)$$

The maximum von Mises stress criteria is based on the von Mises-Hency theory, also known as the Shear-energy theory or the maximum distortion energy theory. The theory states that a ductile material starts to yield at a location when the von Mises stress becomes equal to the limit stress. In most case, the yield strength is used as the stress limit.

$$\sigma_{vm} \leq \sigma_{limit}$$

The safety factor in this condition can be calculated from:

$$N = \frac{\sigma_{limit}}{\sigma_{vm}}$$

The clutch plate is made from High Strength Low Alloy Steels (HSLA). Based on ASM International (8), HSLA has yield strength 297 MPa with the composite as 0.08% C, 0.3% Si, and 0.3% Mn. Increasing the yield point can be done on metal materials, one of which is an effort with Quenching and Tempering as conducted by Yurianto, Pratikto, Rudy S, Wahyono S (9). This condition occurs when the clutch has been operating for a long time, but this research does not focus on this problem.

3. Result and Discussion

It is possible to notice that the value of von mises stress cannot exceed the yield strength of the material used for the clutch plate. If von Mises stress exceed the HSLA steel yield strength of 297 MPa, the clutch disc will be damaged. On the other hand, the role of safety factor has to be considered in order to conduct a good design. The result of the FEA simulation in this study have proven that the Von Mises Stress of the original design is 333.8 MPa in figure 4. Thus, the original design is damaged

during the operation. The biggest stress distribution occurs in the corner area between gaps exactly like the part pointed by the arrow shown by figure 5.

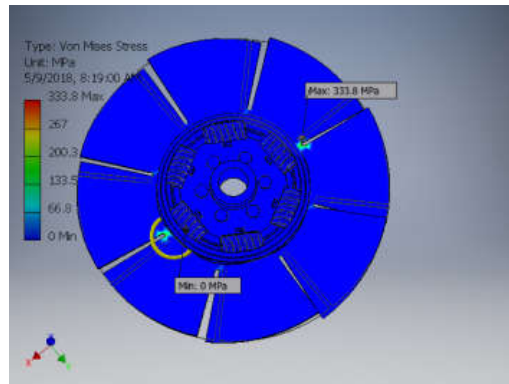

Fig 4 Contour von Mises stress Original.

Design 1 dan 2 in figure 6 are shown the influence of the width of the grooves (L). Thus, the interval of 4.9 mm to 9.9 mm is chosen for the width of the groove (L). The results show that the bigger the width of the grooves, the bigger the value of the von mises stress. Note that the amount of stress based on the interval of the width is from 126.5 MPa to 149.1 MPa. In this case, the area that has the biggest stress is at the part close to the middle plate.

The impact of groove length (P) is analysed on design model 1 and 3. In this simulation, the interval that used for the groove length is from 42.86 mm to 67.86 mm. Based on the result of the simulation, it is possible to see that the maximum stress is happening at the gap between the cushion plate which on the part that has radius. Note that by modifying this variable, the maximum stress applied to the different part of clutch disc. The value of von mises stress are increasing from 149.1 MPa to 152.9 MPa as the groove's length is getting longer based on range of the interval. The simulation result of the design model 3 can be seen on figure 7a. It can be concluded that the design model 3 is fulfilling the criteria because the von Mises Stress is still lower than the yield stress material.

For design model 4, the amount of groove (Z) is modified from originally 8 grooves to only 6 grooves. The model is shown by figure 7b. The result shows that the maximum stress is still applied on the part that has the radius with 292.8 MPa. However, the von mises stress is still lower than the yield strength even though the difference is only a few.

Subsequently, design model 5 is produced by applying different groove's length side by side. The shorter groove is shortened by 45 mm from the original size while the longer groove remains with the original length. The model is shown by figure 7. As a result, the obtained von mises stress from this model is 186.9 MPa. It is possible to see that the part with the longer groove in this design can hold the stress even better compare to the original model.

Afterwards, the application of an angle for the groove is applied on the design model 6 and 7. The model of both can be seen on figure 8a and 8b respectively. The angle of 7.5 degrees is applied for design model 6 while an angle of 5 degrees for design model 7. Same as the results from several previous simulations, the results show that the maximum stress is still happening on the same part. It can be noticed that the von mises stress for design model 6 and 7 are 263.4 MPa and 291 MPa respectively.

Based on the research, it is possible to see that the simulation of several different models produces different variety of result. Figure 9 is showing the value of von mises stress for each design model. There are only 2 design model that are not included into consideration, design model 4 and 7. At the end of this analysis, the lower the value of the von mises stress the better the performance. However, there are a lot of factors that need to re-consider during the production process because sometimes a

very strong model can be considered as over engineered. Therefore, the factors in production process must be included in choosing the best model.

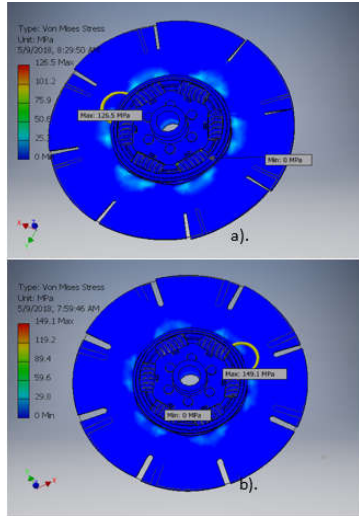

Figure 5 Contour von Mises. a). Design 1 b). Design 2.

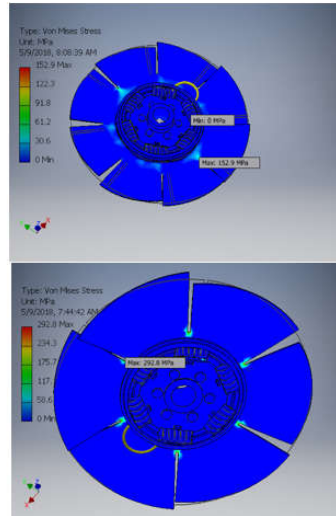

Figure 6 Contour von Mises. a) Design 3 b). Design 4.

In order to get a better result, a further analysis is executed by performing a deeper analysis of the groove's length. This variable is chosen because it has the most significant effect on the model. First further analysis is carried out by making the groove shorter within 5 mm in the interval of 20 mm to 45 mm. After performing the first further analysis, the second further analysis is also executed in order to get a better and more accurate result. In this way, the characteristic of the groove's length can be determined accurately.

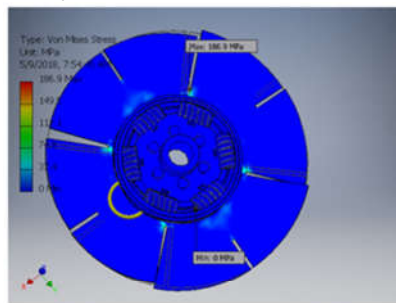

Figure 7 Contour von Mises Design 5

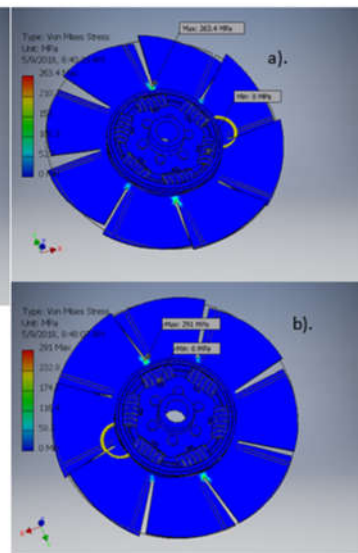

Figure 8 Contour von Mises. a) Design 6 b). Design 7.

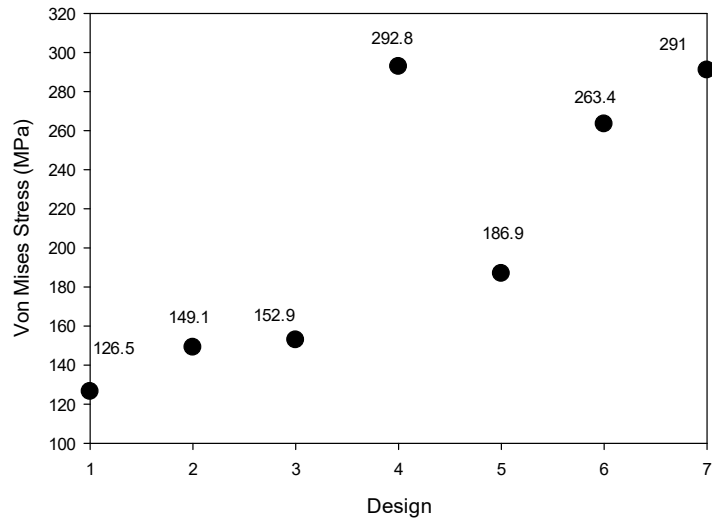

Figure 9 Distribution Von Mises Stress with Variation Design.

Figure 10 is showing the graph of the von mises stress against the groove's length reduction. Von mises stress that is shown on the graph is the result of the simulation based on the different length reduction variables. It can be noted that the best performance of the design is achieved with 121.1 MPa by reducing the groove's length by 35 mm.

The graph of von mises stress against groove's length with 1 mm reduction can be seen on figure 10. The best value of von mises stress that can be seen on the graph is still clutch disc with groove's length 35 mm reduction. However, the difference between one and another is not significant and tend to be very close each other. Even some clutch disc have same value of von mises stress.

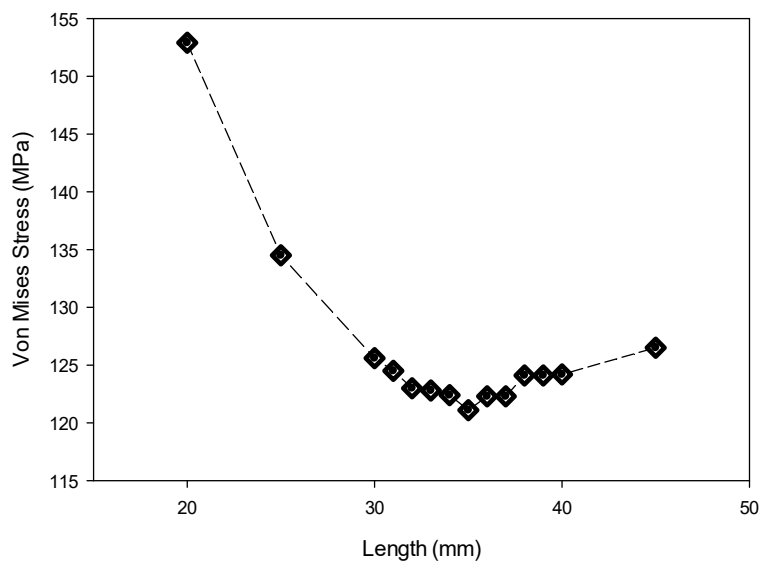

Fig 10 Von Mises Stress against groove's length reduction.

4. Conclusion

There are 7 new design of clutch disc that has been made and be simulated. Those design have different result. Design 1, 2, 3, 5, and 6 are the design that have lower value of von mises stress than 297 MPa which is the value of yield strength of the material. The value of von mises stress of each design is 126.5 MPa, 149.1 MPa, 152.9 MPa, 186.5 MPa, and 263.4 MPa. The lowest value of von mises stress between all those value are design 1 and design 6 has the highest value of von mises stress between all those clutch disc-design. Von mises stress of design 6 is very close with the yield strength of material.

The deeper analysis that has been done too is analysing the characteristic of the groove's length of the clutch plate. Discovering the characteristic of the groove's length can be done with reduce it with 5 mm and 1 mm interval. The best result of the simulation that has been done to the clutch disc with interval 5 mm reduction is owned by clutch disc with 35 mm groove's length reduction and the value is 121.1 MPa. The result of the 1 mm interval reduction is very tight. The difference of the result is very close. Even several clutch disc has same value of von mises stress.

The original model is simulated and the result of the simulation shows that original clutch disc has the value of von mises stress 333.8 MPa. The best design of clutch disc is design 1 with value of von mises stress 126.5 MPa. The original model has higher value of von mises stress than the yield strength of material 297 MPa. However, the best design has lower value of von mises stress than the value of material yield strength. This different characteristic is showed on figure 5. These results made then used in truck operations. Evaluated the resistance of the clutch using vibration analysis. Besides clutch damage can be monitored based on vibrations that occur on machines such as Dedi S and Dicky P (10).

5. References

- [1]. Oday I A and Josep S 2013 *FME Transactions* **41** 317-324
- [2]. Priyanka B C, Patil, Pravin S N, Dhiraj V M 2017 *International Journal for Engineering Trend and Technology* **45** 317-321
- [3]. Vishal D and Nagnath K 2013 *International Journal of Engineering Research and Technology* **2** 3726-3732
- [4]. Lathiya, Badola, Undhad, Dhamecha 2014 *International Journal for Scientific Research and Development* **2** 361-363
- [5]. Efendi and Andoko 2019 Design and Simulation of Cracks in A Four-Cylinder Engine Crankshaft Using Finite Element Method *IOP Conference Series: Material Science and Engineering* **494** 012004.
- [6]. Nanang A S and Femiana G 2019 Rolling Resistance and Noise Estimation for Product Design and Development of Eco-Tyre using Finite Element and Numerical Method *IOP Conference Series : Material Science and Engineering* **494** 012021.
- [7]. Joseph E S and Charles R M 1996 *Mechanical Engineering Design Second Edition* (New York : McGraw-Hill Book Company)
- [8]. ASM International 2001 *Alloying: Understanding the Basic* (#06117G)
- [9]. Yurianto, Pratikto, Rudy S, Wahyono S 2018 *Jurnal Rekayasa Mesin* **9** 143-148
- [10]. Dedi S and Dicky P 2020 *Jurnal Rekayasa Mesin* **3** 21-29