

Cek Plagiarism Paper Telkomnika ALZO

by Indar Sugiarto

Submission date: 16-Sep-2025 04:23PM (UTC+0700)

Submission ID: 2752612987

File name: Telkomnika_ALZO_Sugiarto.pdf (1M)

Word count: 5911

Character count: 29664

ALZO: an outdoor Alzheimer's patient tracking system using internet of things

2

Sugiarto Wibowo, Indar Sugiarto

Department of Electrical Engineering, Faculty of Industrial Technology, Petra Christian University, Surabaya, Indonesia

Article Info

Article history:

Received Mar 13, 2023

Revised Aug 16, 2023

Accepted Sep 22, 2023

Keywords:

Alzheimer

Fall detection

Internet of things

Outdoor tracking system

Wearable device

ABSTRACT

Alzheimer's patients have an abnormal brain that affects some functionalities such as memory and motoric function. Some patients experience disorientation, such as losing their way back home, and impaired lower body motoric function, leading to stumbling. To overcome these problems, we propose a wearable device called Alzo (Alzheimer locator) for tracking Alzheimer patients during outdoor activities. Alzo can detect the patient's location and is also equipped with a fall detection algorithm. The sensor produces an accelerometer and quaternion value, which are used for calculating alpha (represents activity acceleration) and theta (represents body orientation). The location and the patient's fall condition could be monitored using a mobile-based application. The experiments were conducted by operating the Alzo system to detect the patient's location and fall condition. The results showed that Alzo worked for about 3 hours and sent location data 1-5 times if lost or fall detected. Furthermore, thresholds for the fall detection algorithm were 235 m/s² (lower-alpha), 8,108 m/s² (higher-alpha), and 70° (theta). These thresholds were determined based on the experiment which includes standing up, walking, jumping, sitting down, cycling, jogging, bowing, and squatting. From the experiment, the fall detection algorithm achieved 93.33% of accuracy.

This is an open access article under the [CC BY-SA](#) license.



Corresponding Author:

Sugiarto Wibowo

Department of Electrical Engineering, Faculty of Industrial Technology, Petra Christian University

Sivalankerto No.12 31, Surabaya, East Java, Indonesia

Email: osugiartow@gmail.com

1. INTRODUCTION

3

Alzheimer's or dementia Alzheimer's is a disease that attacks the human brain. Most Alzheimer's patients are above 65 years old [1], [2], but it is also possible that younger people are affected, which is known as the early onset. People with dementia Alzheimer's have changes in their behavior, intelligence, and motoric [2]–[4]. The stages of Alzheimer divided into three stages: early (such as forgetting a little thing), mild (such as forgetting the way back home), and moderate (i.e., fully dependent on others and requiring assistance) [5], [6]. Until now, no medicine could cure this disease [7], but there is a method to prevent the degenerative process by being active outdoors, especially in open green spaces. Being outdoors could stimulate the patient's brain to learn again so that the degenerative process will be [8]. When using this method, the problem of getting lost back home will likely increase. Therefore, monitoring patients' outdoor activities is essential to avoid patient loss due to disorientation [9].

The technology could support Alzheimer's patients in daily life. The most common technologies are wearable devices and smartphones to track patient activity outdoors. In recent years, wearable devices have been developed to assist daily human life [6]. Wearable devices are electronic devices that can be attached to the human body, such as a smartwatch, belts, shoes, necklaces, and glasses [10]. A wearable device consists

of electronic components, sensors, and a microcontroller. Wearable devices are closely related to internet of things (IoT). In contrast, IoT could be described as a concept of interconnecting devices to the internet and facilitating data exchange between devices through the internet [6], [10]. In addition, IoT data could be integrated with artificial intelligence (AI) to provide advanced solutions [11].

A wearable device could be equipped with global positioning system (GPS) sensors to track patient location outdoors in real-time [9], [12]. Some studies have already used GPS technology for tracking Alzheimer's patients outdoor [13]–[16]. Adardour *et al.* [17] uses a wearable device shaped like a belt to track patient location using GPS and Wi-Fi to send patient location to a server.

In addition to monitoring patient location, monitoring Alzheimer patients' body movement is also essential. Alzheimer's patient's motoric function is also affected, leading to the risk of stumbling and falls. A fall detection algorithm can use another sensor, such as inertial measurement unit (IMU). Considering the IMU sensor position in a wearable device, it is essential to determine where the wearable device should be attached. Possible wearable device attachment includes the torso, thigh [18], waist [19], wristband [20], eyeglasses [21], and foot [22]. All of those positions could be used to monitor the movement of the human body.

Wearable devices also need network connectivity to communicate through the internet, preferably using wireless technology. The most common wireless technology for wearable devices is mobile cellular (2G, 3G, 4G, 5G), Wi-Fi, long range radio (LoRa), and narrow bandwidth IoT (NB-IoT) [23], [24]. In our work, we use mobile cellular with a 2G signal. In addition to network connectivity, an IoT system also needs a communication protocol such as message queuing telemetry transport (MQTT), constrained application protocol (COAP), extensible messaging and presence protocol (XMPP), and representational state transfer (REST). The MQTT is the most commonly used because it is simple and lightweight. MQTT consists of three entities: a publisher (an entity that publishes data through the MQTT topic), a subscriber (an entity that listens or subscribes to an MQTT topic for reading data), and a broker (a medium that connects the publisher and the subscriber) [25].

This paper describes the development of Alzo, a wearable device with an android-based mobile application that can be used for tracking Alzheimer's patient activity outdoors in real-time. Alzo will be attached to the patient belt and it consists of an IMU sensor, a GPS module, and a mobile cellular (2G) transceiver. The contribution of our work is:

- We leverage IoT technology to support Alzheimer's patients' daily activities.
- We develop an efficient falling algorithm based on IMU data.
- We develop an interactive Alzheimer patient monitoring application with many essential features such as real-time and live patient tracking, geolocation route suggestion, and real-time alarm reporting.

This paper is structured as follows. Section 2 explains our research methodology for designing the wearable device, mobile application and system algorithm. Section 3 discusses the results of our experiments. Section 4 describes the conclusion and future work.

2. METHOD

In this section, we describe Alzo architecture, components of Alzo, tracking and fall detection algorithms, the role of the server in maintaining data, and the design of its accompanying mobile application. The overall architecture of our system is shown in Figure 1. It consists of three parts. The first part is a wearable device that contains a GPS module, an IMU sensor MPU6050, push buttons, an ESP32 microcontroller, and a global system for mobile communications (GSM) module SIM 800L. The second part is a dedicated server for storing data in a database, operating as a broker for MQTT, communicating with the firebase cloud messaging (FCM) service that triggers push notifications [26], and for responding to data requests from Android clients. The third part is the Android mobile application that will be used by caregivers to track the patients.

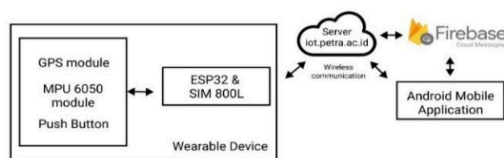

Figure 1. Overall system architecture

2.1. System architecture

Alzo consists of some modules and electronic components. As mentioned before, the wearable device used by the Alzheimer's patient was designed to track the patient location, body position, and orientation. Collected data will be sent to the server as GPS data (latitude, longitude, and timestamp), which will be sent through a mobile cellular signal. Figure 2 shows the schematic diagram of the proposed wearable device. The wearable device consists of a GPS module U-Blox NEO-6M, an IMU sensor MPU6050 that consist of accelerometer and gyroscope sensors, an organic light-emitting diodes (OLED) display to show current timestamp, and two push buttons (for turn on the device and send GPS data to the server manually). It is also equipped with a 400 mAH lithium polymer (LiPo) battery and a charging module, including a battery management system (BMS). Moreover, SIM 800L module was used for internet connectivity.

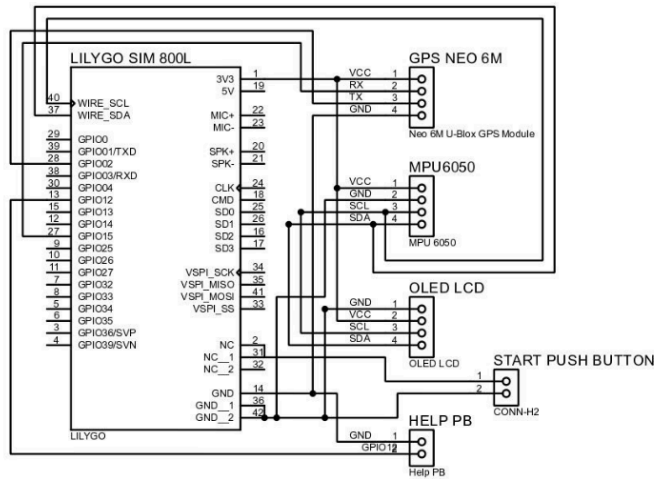

Figure 2. Alzo's schematic diagram

Alzo is packaged into a casing made using a 3D printer, as shown in Figure 3. Figure 3(a) is the right side which consists of a charging port, Figure 3(b) is the bottom side which consists of a button for turning on/off the system; Figure 3(c) is the backside which contains a hook part for attaching to the patient belt; Figure 3(d) is the front side which consists of help push button and OLED display. The dimension of the wearable device in total is 14.5x3.5x7.5 (including the casing). In the future, it could be resized smaller by embedding all the components and modules into one board.

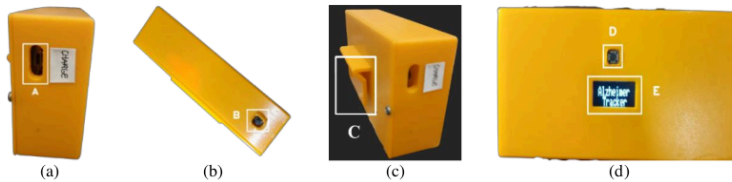

Figure 3. Alzo casing overview: (a) right side, (b) bottom side, (c) backside, and (d) front side

The workflow of the Alzo program is shown in Figure 4. When the device is turned on, the first thing that will be executed is the initialization of the GPS module, MPU6050 sensor, OLED display module, and general-purpose input output (GPIO) pins of the LilyGo. Afterward, the program connects to a provider of subscriber identity module (SIM). If successful, the program will attempt to connect with the access point name (APN) provider for internet access. With internet access capability, Alzo could connect to an MQTT broker. After connecting to the MQTT broker will show a timestamp on OLED display, which indicates the wearable device's readiness. The program also detects whether the help push button was pressed; if pressed, Alzo will send GPS data (latitude, longitude, timestamp, and lost condition) to the server through the declared MQTT topic. Otherwise, the program will try to detect the patient body position that will be used by the fall detection algorithm. If a fall is detected, then it will send GPS data (latitude, longitude, timestamp, and fall condition) to the server through the same MQTT topic as before.

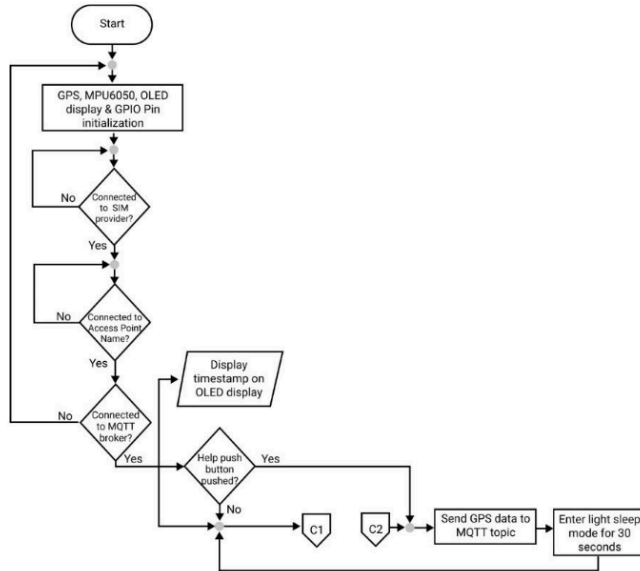

Figure 4. Alzo main flowchart

2.2. Fall detection algorithm

We use a fall detection algorithm using a threshold mechanism similar to [27]. In our proposed algorithm, three types of thresholds will be used: lower-alpha threshold, higher-alpha threshold, and theta threshold. Lower alpha indicates the patient is active or doing some activity, while higher alpha means rapid acceleration of patient activity. Moreover, theta indicates the patient's body orientation changed rapidly after quick acceleration.

Alpha is the sum of acceleration in triaxial axes; when the patient moves, they will produce acceleration in every axis. The sum could be calculated to make the total acceleration of patient movement. Furthermore, theta is the calculation of quaternion in triaxial axes, where quaternion is a complex mathematical calculation to detect rotation. The authors considered the threshold-based algorithm suitable for this compact wearable device because of the simpler computation for LilyGo. In contrast, machine learning algorithm has complex computational requiring higher microcontroller specification. In addition, alpha and theta are given by the following (1) and (2):

ALZO: an outdoor Alzheimer's patient tracking system using internet of things (Sugiarto Wibowo)

$$|a|(Alpha) = \sqrt{a_x^2 + a_y^2 + a_z^2} \tag{1}$$

$$\theta (Theta) = 2 \times \arctan\left(\frac{\sqrt{q_1^2 + q_2^2 + q_3^2}}{q_0}\right) \times \frac{180}{3.14} \tag{2}$$

Figure 5 visualizes the computation flow of our proposed fall detection algorithm. This latter begins with capturing accelerometer and quaternion data from digital motion processor (DMP) feature in MPU6050. Afterwards, the program will calculate the alpha value from accelerometer data. If the value is greater than the lower-alpha threshold, it indicates the patient is actively doing everyday activities. It then continues to calculate the alpha value again, and if this time the alpha value is greater than the higher-alpha threshold, then it indicates the patient accelerates significantly. If the patient's acceleration cuts through higher-alpha threshold, then the algorithm will continue calculating the theta value. Next, if theta value is bigger than the threshold it indicates the patient's body orientation changed significantly. If the theta value is greater than the threshold for more than 10 seconds, then it could be concluded that the patient is fallen.

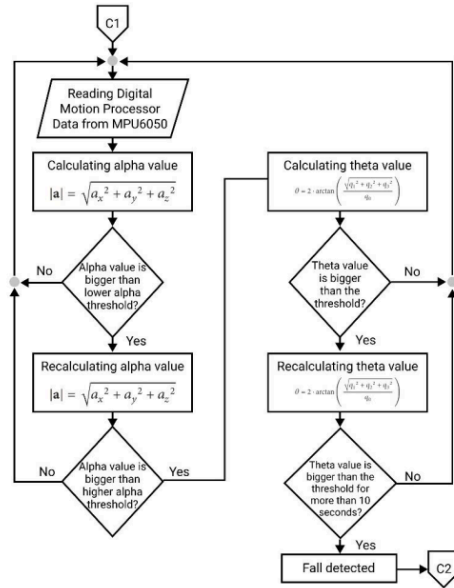
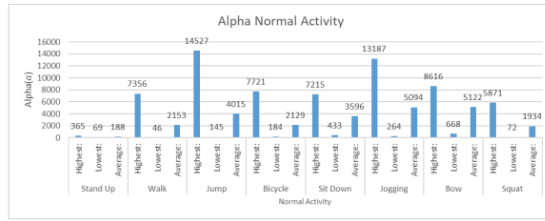

Figure 5. Fall detection algorithm

Table 1 shows all the thresholds that were obtained by doing some experiments on everyday activities such as standing up, walking, jumping, cycling, sitting down, jogging, bowing, and squatting, as well as falling actions such as falling forward, backwards, fall to the left and fall to the right. Figure 6(a) visualizes alpha, and Figure 6(b) theta values corresponding to the experiment's every day, while Figures 6(c) and (d) show fall activities. Everyday activities were analyzed by calculating the lowest, highest, and average alpha and theta values. In contrast, falling conditions were analyzed by calculating the lowest, highest, and stationary alpha and theta values. From Figures 6(a) and (b), we can see that alpha and theta values in everyday activity are not directly proportional, whereas, in Figures 6(c) and (d), both values are directly proportional.

Table 1. Threshold value for the fall detection algorithm

Threshold	Description
Lower-alpha	235
Higher-alpha	8,108
Theta	70 (80-10)
	Average of alpha everyday activity
	Average of the highest alpha value in everyday activity
	The average of theta value while the body is lying down on the floor and the tolerance is -10 (because the lowest value of theta while lying down on the floor is 70.15)



(a)

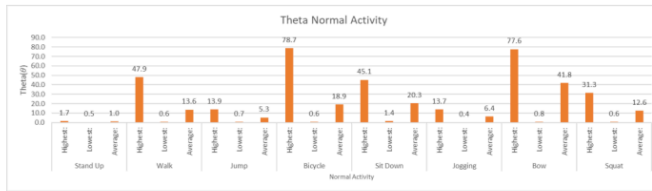

(b)

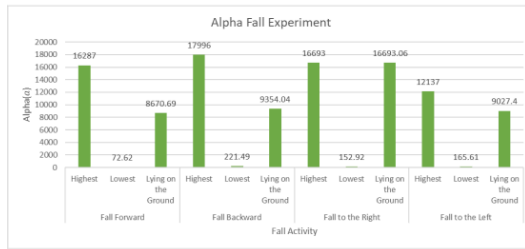

(c)

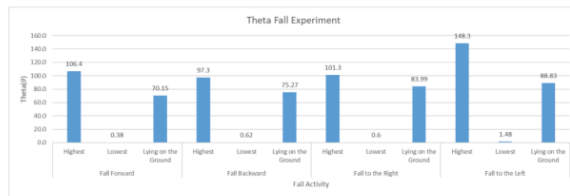

(d)

Figure 6. Experiments to determine each threshold; (a) alpha data in everyday activity, (b) theta data in everyday activity, (c) alpha data in fall experiment, and (d) theta data in fall experiment

2.3. Server configuration

A dedicated server is used for maintaining data. The server has functions for storing data in the database, communicating with FCM, receiving data from a wearable device (Alzo), and responding to the android client application requests. Flask is used for handling HTTP requests, MySQL is used for the database, and an MQTT broker is used for handling telemetry messages between Alzo and the server. The overall server workflow is shown in Figure 7. The server will retrieve the patient deviceID from the database; then, the deviceID will be used for the MQTT topic subscription. If the MQTT topic receives data, the server will notify the FCM server first and store the data in the MySQL database. Flask will detect the incoming request from the android client and retrieve data from the database to be sent back to the Android client.

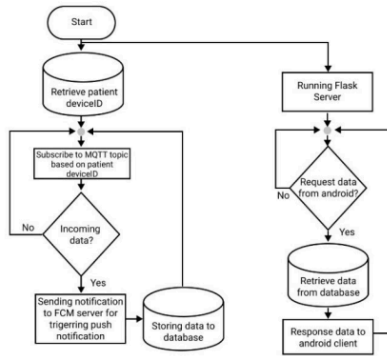

Figure 7. Server flowchart

2.4. Mobile monitoring application

Patient caregivers will use an android-based mobile application to monitor patient activities. Figure 8 represents the use case diagram of the Android mobile application, where the user is the caregiver. The caregiver must first login when opening the application with the username and password registered in the database. After login, the caregiver can view program features such as caregiver profile information and patient activity dashboard. Within the patient activity monitoring dashboard, the caregiver can refresh data, back to the home page, or find a direction to the patient's location. The tracking visualization is shown in Figure 9; caregivers could track the patient's location using a map including the last timestamp, patient condition, address of patient's location, and caregiver's current location. Caregivers can also find the direction to the patient's location and refresh the tracking data.

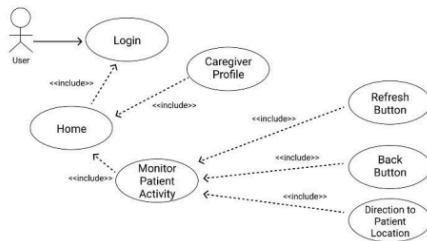

Figure 8. Android client use case diagram

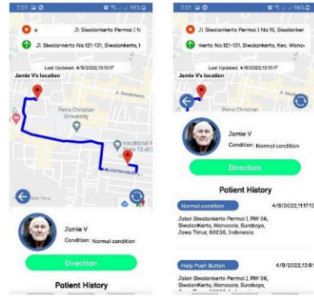

Figure 9. Monitoring patient activity via a dashboard

3. RESULTS AND DISCUSSION

The experiments were conducted by operating Alzo and the accompanying android application. Two main aspects need to be evaluated: the tracking algorithm (lost and fall detection algorithm) performance and the durability of the wearable device battery during operation. Alzo was operated using a 400 mAh battery. Alzo sends GPS data 1-5 times during the experiment while working for 3 hours and runs a fall detection algorithm. The experiment was performed twice in which Alzo operated for 3 hours 15 minutes and 3 hours 2 minutes, respectively. We measure the current consumption during the operation, and the result is listed in Table 2. The battery durability seems to be affected by some factors, such as lousy signal while connecting to GSM, MQTT broker, GPS satellite, and the environment's temperature.

For testing the fall detection algorithm, we used the wearable device attached to the belt and does the everyday as well as fall activities by letting the body to fall to the floor. There are three types of falls that were tested: fall forward, fall backward, and fall aside as shown in Figure 10. As a for mentioned (see Table 1 as well), there are four conditions that can be used to detect the fall: i) 1st condition= α value > lower-alpha threshold (235); ii) 2nd condition=1st condition is met and α value > higher-alpha threshold (8,108); iii) 3rd condition=2nd condition is met and θ value > theta threshold (70); and iv) 4th condition=3rd condition is met and θ value > theta threshold (70) for more than 10 seconds. These conditions were summarized in Tables 3 and 4. As shown in Table 3, Alzo doesn't produce a false statement about the condition. In fact, the 3rd and 4th conditions were never met. Therefore, the fall condition is not detected. Table 4 shows that the fall activity is detected accurately. In every fall testing activity, the 4th condition was always met.

Table 2. Current measurements of Alzo during experiments

Task	Current range (A)
Connecting to GSM	0.180–0.208
Connecting to MQTT broker	0.150–0.170
Reading GPS data from GPS module	0.125–0.167
Reading data from MPU6050	0.160–0.244
Sending data to MQTT topic	0.120–0.134
Displaying data to OLED display	0.220–0.260
Entering the light mode sleep for 30 seconds	0.070–0.088
Reading help push button state	0.112–0.122



Figure 10. Testing falls activity illustration

Table 3. Everyday activity testing

Activity	Alpha	Theta	1st	2nd	3rd	4th	N Second	Activity	Alpha	Theta	1st	2nd	3rd	4th	N Second
	187	1	-	-	-	-	1		1536	3	√	-	-	-	1
	174	1	-	-	-	-	2		4013	7	√	-	-	-	2
	153	1	-	-	-	-	3		7327	7	√	-	-	-	3
	111	1	-	-	-	-	4		2500	6	√	-	-	-	4
	69	1	-	-	-	-	5		1204	5	√	-	-	-	5
	119	1	-	-	-	-	6		4833	6	√	-	-	-	6
	77	1	-	-	-	-	7		10339	11	√	√	-	-	7
	78	1	-	-	-	-	8		4954	8	√	-	-	-	8
	128	1	-	-	-	-	9		8996	5	√	-	-	-	9
	184	1	-	-	-	-	10		7228	5	√	-	-	-	10
Standing Up	131	1	-	-	-	-	11	Jogging	3454	5	√	-	-	-	11
	224	1	-	-	-	-	12		6100	8	√	-	-	-	12
	293	1	√	-	-	-	13		1189	6	√	-	-	-	13
	345	1	√	-	-	-	14		735	6	√	-	-	-	14
	365	1	√	-	-	-	15		3048	5	√	-	-	-	15
	353	1	√	-	-	-	16		7347	7	√	-	-	-	16
	215	1	-	-	-	-	17		4590	9	√	-	-	-	17
	244	1	√	-	-	-	18		9256	7	√	√	-	-	18
	225	1	-	-	-	-	19		6029	11	√	-	-	-	19
	179	2	-	-	-	-	20		9345	8	√	√	-	-	20
	775	1	√	-	-	-	1		4203	8	√	-	-	-	1
	789	1	√	-	-	-	2		4426	7	√	-	-	-	2
	801	2	√	-	-	-	3		4658	9	√	-	-	-	3
	820	2	√	-	-	-	4		5267	8	√	-	-	-	4
	54	2	-	-	-	-	5		5455	9	√	-	-	-	5
	644	1	√	-	-	-	6		5583	6	√	-	-	-	6
	2089	3	√	-	-	-	7		5679	4	√	-	-	-	7
	1534	4	√	-	-	-	8		5807	3	√	-	-	-	8
	499	5	√	-	-	-	9		6008	3	√	-	-	-	9
Walking	1763	8	√	-	-	-	10	Bowing	6121	3	√	-	-	-	10
	1498	5	√	-	-	-	11		6147	4	√	-	-	-	11
	1002	2	√	-	-	-	12		5836	7	√	-	-	-	12
	1219	1	√	-	-	-	13		5346	12	√	-	-	-	13
	2452	2	√	-	-	-	14		5123	14	√	-	-	-	14
	957	6	√	-	-	-	15		5363	15	√	-	-	-	15
	1475	6	√	-	-	-	16		5358	16	√	-	-	-	16
	2845	6	√	-	-	-	17		5358	18	√	-	-	-	17
	1553	3	√	-	-	-	18		5372	20	√	-	-	-	18
	1076	2	√	-	-	-	19		5350	21	√	-	-	-	19
	3254	2	√	-	-	-	20		5758	21	√	-	-	-	20
	823	4	√	-	-	-	1		264	2	√	-	-	-	1
	1193	5	√	-	-	-	2		697	1	√	-	-	-	2
	2090	6	√	-	-	-	3		875	3	√	-	-	-	3
	1360	7	√	-	-	-	4		1136	4	√	-	-	-	4
	1887	5	√	-	-	-	5		418	6	√	-	-	-	5
	2760	4	√	-	-	-	6		2581	11	√	-	-	-	6
	10321	6	√	√	-	-	7		2893	11	√	-	-	-	7
	5301	5	√	-	-	-	8		3069	3	√	-	-	-	8
	2092	2	√	-	-	-	9		1609	5	√	-	-	-	9
Jumping	1856	4	√	-	-	-	10	Squatting	1605	3	√	-	-	-	10
	4159	4	√	-	-	-	11		1148	2	√	-	-	-	11
	1909	6	√	-	-	-	12		943	2	√	-	-	-	12
	3896	3	√	-	-	-	13		1005	2	√	-	-	-	13
	3284	2	√	-	-	-	14		938	3	√	-	-	-	14
	1981	4	√	-	-	-	15		1564	7	√	-	-	-	15
	724	4	√	-	-	-	16		662	11	√	-	-	-	16
	4925	7	√	-	-	-	17		2401	12	√	-	-	-	17
	11283	2	√	√	-	-	18		2874	10	√	-	-	-	18
	5813	7	√	-	-	-	19		1635	7	√	-	-	-	19
	1904	3	√	-	-	-	20		786	6	√	-	-	-	20
	1003	4	√	-	-	-	1		1347	3	√	-	-	-	1
	1232	4	√	-	-	-	2		1982	5	√	-	-	-	2
	1281	4	√	-	-	-	3		2226	7	√	-	-	-	3
	1296	5	√	-	-	-	4		2640	6	√	-	-	-	4
	2197	13	√	-	-	-	5		1867	8	√	-	-	-	5
	2659	22	√	-	-	-	6		3937	17	√	-	-	-	6
	3545	31	√	-	-	-	7		3193	21	√	-	-	-	7
	2951	40	√	-	-	-	8		3086	19	√	-	-	-	8
	2729	49	√	-	-	-	9		3253	19	√	-	-	-	9
Cycling	2855	56	√	-	-	-	10	Sit Down	3555	21	√	-	-	-	10
	3670	64	√	-	-	-	11		4169	22	√	-	-	-	11
	4233	71	√	-	-	-	12		4968	25	√	-	-	-	12
	4182	77	√	-	-	-	13		6045	30	√	-	-	-	13
	5724	79	√	-	-	-	14		6151	28	√	-	-	-	14
	4769	78	√	-	-	-	15		5616	24	√	-	-	-	15
	5279	71	√	-	-	-	16		5378	22	√	-	-	-	16
	6328	58	√	-	-	-	17		5200	20	√	-	-	-	17
	7111	53	√	-	-	-	18		5301	19	√	-	-	-	18
	7721	44	√	-	-	-	19		5033	17	√	-	-	-	19
	6541	38	√	-	-	-	20		4621	14	√	-	-	-	20

Table 4. Fall activity testing

Activity	Alpha	Theta	1st	2nd	3rd	4th	N Second	Activity	Alpha	Theta	1st	2nd	3rd	4th	N Second
	9354	75.27	√	√	√	-	1	12137	117	√	√	√	√	-	1
	13993	79.61	√	√	√	-	2	10224	139	√	√	√	√	-	2
	13114	86.95	√	√	√	-	3	11335	148	√	√	√	√	-	3
	8557	85.57	√	√	√	-	4	9126	135	√	√	√	√	-	4
	11081	77.07	√	√	√	-	5	8557	86	√	√	√	√	-	5
	11526	75.64	√	√	√	-	6	9027	89	√	√	√	√	-	6
	10700	76.32	√	√	√	-	7	11871	89	√	√	√	√	-	7
	10684	76.81	√	√	√	-	8	11608	89	√	√	√	√	-	8
	11283	76.21	√	√	√	-	9	11609	85	√	√	√	√	-	9
Fall Forward 1	10816	76.23	√	√	√	√	10	10233	84	√	√	√	√	√	10
	10603	76.08	√	√	√	√	11	10997	82	√	√	√	√	√	11
	10489	77.02	√	√	√	√	12	10735	83	√	√	√	√	√	12
	11105	79.32	√	√	√	√	13	10877	84	√	√	√	√	√	13
	10875	79.91	√	√	√	√	14	10491	83	√	√	√	√	√	14
	10753	79.92	√	√	√	√	15	10608	81	√	√	√	√	√	15
	10620	79.97	√	√	√	√	16	10101	80	√	√	√	√	√	16
	10667	79.95	√	√	√	√	17	10249	80	√	√	√	√	√	17
	10737	80.12	√	√	√	√	18	10220	81	√	√	√	√	√	18
	10843	80.58	√	√	√	√	19	10162	81	√	√	√	√	√	19
	10749	80.85	√	√	√	√	20	10011	81	√	√	√	√	√	20
	14603	52	√	√	√	-	1	16693	84	√	√	√	√	-	1
	11949	45	√	√	√	-	2	12513	101	√	√	√	√	-	2
	11620	45	√	√	√	-	3	12903	101	√	√	√	√	-	3
	11065	42	√	√	√	-	4	12655	96	√	√	√	√	-	4
	10272	38	√	√	√	-	5	11724	88	√	√	√	√	-	5
	9314	37	√	√	√	-	6	8842	88	√	√	√	√	-	6
	8671	39	√	√	√	-	7	11765	93	√	√	√	√	-	7
	7966	43	√	√	√	-	8	10487	100	√	√	√	√	-	8
	6819	48	√	√	√	-	9	10917	100	√	√	√	√	-	9
Fall Forward 2	8671	70	√	√	√	√	10	11459	92	√	√	√	√	√	10
	5306	56	√	√	√	-	11	10701	89	√	√	√	√	-	11
	4762	59	√	√	√	-	12	11740	85	√	√	√	√	-	12
	4374	62	√	√	√	-	13	11473	85	√	√	√	√	-	13
	8823	103	√	√	√	√	14	11152	85	√	√	√	√	√	14
	10334	106	√	√	√	√	15	11971	86	√	√	√	√	√	15
	11182	104	√	√	√	√	16	10617	88	√	√	√	√	√	16
	10701	96	√	√	√	√	17	12023	88	√	√	√	√	√	17
	9632	86	√	√	√	√	18	11535	91	√	√	√	√	√	18
	8872	78	√	√	√	√	19	10780	89	√	√	√	√	√	19
	7807	69	√	√	√	-	20	10608	84	√	√	√	√	√	20
	16693	84	√	√	√	-	1	11871	89	√	√	√	√	-	1
	12513	101	√	√	√	-	2	11608	89	√	√	√	√	-	2
	12903	101	√	√	√	-	3	11609	85	√	√	√	√	-	3
	12655	96	√	√	√	-	4	10233	84	√	√	√	√	-	4
	11724	88	√	√	√	-	5	10997	82	√	√	√	√	-	5
	8842	88	√	√	√	-	6	10735	83	√	√	√	√	-	6
	11765	93	√	√	√	-	7	10877	84	√	√	√	√	-	7
	10487	100	√	√	√	-	8	10491	83	√	√	√	√	-	8
	10917	100	√	√	√	-	9	10608	81	√	√	√	√	-	9
Fall Backward 1	11459	92	√	√	√	√	10	10101	80	√	√	√	√	√	10
	10701	89	√	√	√	√	11	10249	80	√	√	√	√	√	11
	11740	85	√	√	√	√	12	10220	81	√	√	√	√	√	12
	11473	85	√	√	√	√	13	10162	81	√	√	√	√	√	13
	11152	85	√	√	√	√	14	10011	81	√	√	√	√	√	14
	11971	86	√	√	√	√	15	10223	81	√	√	√	√	√	15
	10617	88	√	√	√	√	16	10122	81	√	√	√	√	√	16
	12023	88	√	√	√	√	17	10096	84	√	√	√	√	√	17
	11535	91	√	√	√	√	18	10156	84	√	√	√	√	√	18
	10780	89	√	√	√	√	19	9865	83	√	√	√	√	√	19
	10608	84	√	√	√	√	20	10024	83	√	√	√	√	√	20
	9354	75	√	√	√	-	1								
	13993	80	√	√	√	-	2								
	11081	77	√	√	√	-	3								
	11526	76	√	√	√	-	4								
	10700	76	√	√	√	-	5								
	10684	77	√	√	√	-	6								
	10603	76	√	√	√	-	7								
	10489	77	√	√	√	-	8								
	11105	79	√	√	√	-	9								
Fall Backward 2	10875	80	√	√	√	√	10								
	10753	80	√	√	√	√	11								
	10620	80	√	√	√	√	12								
	10667	80	√	√	√	√	13								
	10737	80	√	√	√	√	14								
	10843	81	√	√	√	√	15								
	10749	81	√	√	√	√	16								
	10801	81	√	√	√	√	17								
	10777	81	√	√	√	√	18								
	10740	82	√	√	√	√	19								
	10735	82	√	√	√	√	20								

The accuracy of the fall detection algorithm can be determined from Tables 3 and 4. There are eight activities and seven fall actions. As shown in Table 3, among eight recorded activities, the algorithm never falsely recognized normal activities as fall conditions. Whereas in Table 4, the algorithm recognized six fall conditions out of seven activities. From these tables, the algorithm accuracy can be computed based on the number of activities that are not recognized as fall conditions (X_1), and activities that are recognized as fall conditions (X_2). The equation to determine the accuracy of the algorithm is as (3):

$$Accuracy = \frac{X_1 + X_2}{Total\ experiments} * 100 \quad (3)$$

where $X_1=8$, $X_2=6$, and the total experiments=15
Therefore,

$$Accuracy = \frac{8+6}{15} * 100 \\ = 93.33\%$$

4. CONCLUSION

This paper presents a system that can monitor and track Alzheimer's patients during their outdoor activities. The system, called Alzo, is implemented as a wearable device. It is equipped with location tracking and fall detection capabilities. The system also has a mobile application companion that helps the patient's caregivers to monitor the location and condition of patients easily. The fall detection algorithm was implemented using a threshold detection that operates on three body position values collected by an IMU sensor: 235 m/s^2 (lower-alpha), $8,108 \text{ m/s}^2$ (higher-alpha), and 70° (theta). The experiments showed that Alzo can correctly detect the patient's location and fall condition. The fall detection experiments include various position: standing up, jogging, walking, bowing, jumping, squatting, cycling, sit down, fall forward, fall aside, and fall backwards. From the experiment, the accuracy of the fall detection algorithm is calculated as 93.33%. To make fall detection more robust, we plan to implement a more complex machine-learning algorithm in our future work. Consequently, more actual data from real Alzheimer patients will be needed, which should be addressed in a complete and more comprehensive experimental setup.

ACKNOWLEDGEMENTS

The authors would like to thank Lembaga Penelitian dan Pengabdian Masyarakat (LPPM) of Petra Christian University for supporting our work through the special research grant No. 111-BK-PENELITIAN/LPPM-UKP/XI/2022. The authors also acknowledge the financial support from the Ministry of Education, Culture, Research, and Technology of Indonesia under the research grant No. 02/AMD/SP2H/PT-LLL/7/2022.

REFERENCES

- [1] P. Shenoi, P. Baheria, S. Jose, S. Kumar, and J. S. Nayak, "Wearable Tracking Device for Alzheimer's Patients: A Survey," *10/R*, vol. 3, no. 4, 2016.
- [2] N. Gillani and T. Arslan, "Intelligent Sensing Technologies for the Diagnosis, Monitoring and Therapy of Alzheimer's Disease: A Systematic Review," *Sensors*, vol. 21, no. 12, p. 4249, Jun. 2021, doi: 10.3390/s21124249.
- [3] H. Ashrafiyan, E. H. Zadeh, and R. H. Khan, "Review on Alzheimer's disease: Inhibition of amyloid beta and tau tangle formation," *International Journal of Biological Macromolecules*, vol. 167, pp. 382-394, Jan. 2021, doi: 10.1016/j.ijbiomac.2020.11.192.
- [4] A. M. Al-Harasi et al., "Motor signs in Alzheimer's disease and vascular dementia: Detection through natural language processing, co-morbid features and relationship to adverse outcomes," *Experimental Gerontology*, vol. 146, p. 111223, Apr. 2021, doi: 10.1016/j.exger.2020.111223.
- [5] P. Maresova, J. Hruska, B. Klimova, S. Barakovic, and O. Krejcar, "Activities of Daily Living and Associated Costs in the Most Widespread Neurodegenerative Diseases: A Systematic Review," *Clinical Interventions in Aging*, vol. Volume 15, pp. 1841-1862, Oct. 2020, doi: 10.2147/CIA.S264688.
- [6] W. Salehi, G. Gupta, S. Bhatia, D. Koundal, A. Mashat, and A. Belay, "IoT-Based Wearable Devices for Patients Suffering from Alzheimer Disease," *Contrast Media & Molecular Imaging*, vol. 2022, pp. 1-15, Apr. 2022, doi: 10.1155/2022/3224939.
- [7] H. Sun, A. Wang, W. Wang, and C. Liu, "An Improved Deep Residual Network Prediction Model for the Early Diagnosis of Alzheimer's Disease," *Sensors*, vol. 21, no. 12, p. 4182, Jun. 2021, doi: 10.3390/s21124182.
- [8] L. Besser, "Outdoor green space exposure and brain health measures related to Alzheimer's disease: a rapid review," *BMJ Open*, vol. 11, no. 5, p. e043456, May 2021, doi: 10.1136/bmjopen-2020-043456.
- [9] V. Puthusseryppady, S. Morrissey, M. H. Aung, G. Coughlan, M. Patel, and M. Homberger, "Using GPS Tracking to Investigate Outdoor Navigation Patterns in Patients With Alzheimer Disease: Cross-sectional Study," *JMIR Aging*, vol. 5, no. 2, p. e28222, Apr. 2022, doi: 10.2196/28222.

- 1
- [10] A. Sheikhtaheri and F. Sabermahani, "Applications and Outcomes of Internet of Things for Patients with Alzheimer's Disease/Dementia: A Scoping Review," *BioMed Research International*, vol. 2022, pp. 1–17, Mar. 2022, doi: 10.15520226274185.
- [11] T. G. Stavropoulos, A. Papastergiou, L. Mpaltadoros, S. Nikolopoulos, and I. Kompatsiaris, "IoT Wearable Sensors and Devices in Elderly Care: A Literature Review," *Sensors*, vol. 20, no. 10, p. 2826, May 2020, doi: 10.3390/s20102826.
- [12] N. Firougrahi et al., "The role of geographic information systems and global positioning system in dementia care and research: a scoping review," *International Journal of Health Geographics*, vol. 21, no. 1, p. 8, Aug. 2022, doi: 10.1186/s12942-022-00308-1.
- [13] C. K. Behera, J. Condeell, S. Dora, D. S. Gibson, and G. Leavey, "State-of-the-Art Sensors for Remote Care of People with Dementia during a Pandemic: A Systematic Review," *Sensors*, vol. 21, no. 14, p. 4688, Jul. 2021, doi: 10.3390/s21144688.
- [14] A. Cullen, M. K. A. Mazhar, M. D. Smith, F. E. Lithander, M. O. Breasail, and E. J. Henderson, "Wearable and Portable GPS Solutions for Monitoring Mobility in Dementia: A Systematic Review," *Sensors*, vol. 22, no. 9, p. 3336, Apr. 2022, doi: 10.3390/s22093336.
- [15] M. Muurling et al., "Remote monitoring technologies in Alzheimer's disease: design of the RADAR-AD study," *Alzheimer's Research & Therapy*, vol. 13, no. 1, p. 89, Dec. 2021, doi: 10.1186/s13195-021-00825-4.
- [16] C. H. Teoh, H. L. Khoo, R. Komiya, "A novel dynamic localisation system for indoor and outdoor tracking," *Journal of Location Based Services*, vol. 13, no. 3, pp. 178–212, Jul. 2019, doi: 10.1080/17489725.2019.1606459.
- [17] H. E. Adardour, M. Hadjila, S. M. H. Irid, T. Baouch, and S. E. Belkhter, "Outdoor Alzheimer's Patients Tracking Using an IoT System and a Kalman Filter Estimator," *Wireless Personal Communications*, vol. 116, no. 1, pp. 249–265, Jan. 2021, doi: 10.1007/s11277-020-07713-4.
- [18] B. R. Greene, E. P. Doheny, K. McManus, and B. Caulfield, "Estimating balance, cognitive function, and falls risk using wearable sensors and the sit-to-stand test," *Wearable Technologies*, vol. 3, p. e9, Jun. 2022, doi: 10.1017/wtc.2022.6.
- [19] A. Jefiza, E. Prumnanto, H. Boedinogroho, and M. H. Pumomo, "Fall detection based on accelerometer and gyroscope using back propagation," in *2017 4th International Conference on Electrical Engineering, Computer Science and Informatics (EECSI)*, Sep. 2017, pp. 1–12, doi: 10.1109/EECSI.2017.8239149.
- [20] G. Gingras, M. Adda, and A. Bouzouane, "Toward a Non-Intrusive, Affordable Platform for Elderly Assistance and Health Monitoring," in *2020 IEEE 44th Annual Computers, Software, and Applications Conference (COMPSAC)*, Jul. 2020, pp. 699–84, doi: 10.1109/COMPSAC48688.2020.0-178.
- [21] C.-L. Lin, W.-C. Chiu, F.-H. Chen, Y.-H. Ho, T.-C. Chu, and P.-H. Hsieh, "Fall Monitoring for the Elderly Using Wearable Inertial Measurement Sensors on Eyeglasses," *IEEE Sensors Letters*, vol. 4, no. 6, pp. 1–4, Jun. 2020, doi: 10.1109/LENS.2020.2996746.
- [22] H. Chandler et al., "Wearable Stretch Sensors for Human Movement Monitoring and Fall Detection in Ergonomics," *International Journal of Environmental Research and Public Health*, vol. 17, no. 10, p. 3554, May 2020, doi: 10.3390/ijerph17103554.
- [23] T. G. Durand, L. Visagie, and M. J. Booysen, "Evaluation of next-generation low-power communication technology to replace 4G in IoT-applications," *IET Communications*, vol. 13, no. 16, pp. 2533–2540, Oct. 2019, doi: 10.1049/iet-com.2019.0168.
- [24] M. S. A. Muthanna, P. Wang, M. Wei, A. Abuarqoub, A. Alzu'bi, and H. Gull, "Cognitive control models of multiple access IoT networks using LoRa technology," *Cognitive Systems Research*, vol. 65, pp. 62–73, Jan. 2021, doi: 10.1016/j.cogsys.2020.09.002.
- [25] C. Patel and N. Doshi, "A Novel MQTT Security framework In Generic IoT Model," *Procedia Computer Science*, vol. 171, pp. 1399–1408, 2020, doi: 10.1016/j.procs.2020.04.150.
- [26] J.-D. Kim, S.-Y. Lee, Y.-S. Kim, H.-J. Song, and C.-Y. Park, "A study of polymerase chain reaction device control via cloud using Firebase Cloud Messaging protocol," *BioMedical Engineering OnLine*, vol. 17, no. S2, p. 153, Nov. 2018, doi: 10.1186/s12938-018-0585-2.
- [27] F. Wu, H. Zhao, Y. Zhao, and H. Zhong, "Development of a Wearable-Sensor-Based Fall Detection System," *International Journal of Telemedicine and Applications*, vol. 2015, pp. 1–11, 2015, doi: 10.1155/2015/576364.

BIOGRAPHIES OF AUTHORS



Sugiarto Wibowo received the Bachelor of Engineering degree in Electrical Engineering from the Petra Christian University, Surabaya, East Java, Indonesia, in 2022. He is currently an Embedded Software Engineer, Department of Research and Development, Poltron Indonesia (PT. Hartono Istana Teknologi). His research interests are embedded systems and machine vision. He can be contacted at email: osugiartow@gmail.com.



Indar Sugiarto obtained Ph.D. degree from Technische Universität München in 2015. His researches are in fields of supercomputing, artificial intelligence, embedded systems, and robotics. He is a senior lecturer in Electrical Engineering Department of Petra Christian University. He is also affiliated with IEEE and ACM as an active senior member. Currently he serves as an officer for the Indonesian Chapter of IEEE Computer Society. He is also the Deputy of Artificial Intelligence Research Center at Petra Christian University. He can be contacted at email: indi@petra.ac.id.

Cek Plagiarism Paper Telkomnika ALZO

ORIGINALITY REPORT

15%	%	15%	%
SIMILARITY INDEX	INTERNET SOURCES	PUBLICATIONS	STUDENT PAPERS

PRIMARY SOURCES

- 1 R. Latha, R. Ramya, U. Arul, Nilamadhab Mishra, S. Dhanalakshmi. "Cloud-Based Smart Sensing System for Real-Time Health Management of Dementia Patients", 2023 Second International Conference On Smart Technologies For Smart Nation (SmartTechCon), 2023
Publication 2%
- 2 Handy Wicaksono, Petrus Santoso, Indar Sugiarto, Sean Gondowardoyo, Andrew Wijaya, Jason Halim, Nazhatul Hafizah Kamarudin. "The integrated smart system to assist elderly at home", IAES International Journal of Artificial Intelligence (IJ-AI), 2024
Publication 2%
- 3 Santiago Linder Rubiños Jimenez, Juan Herber Grados Gamarra, Eduardo Nelson Chávez Gallegos, Linett Angélica Velasquez Jimenez et al. "Wearable with integrated piezoelectric energy harvester for geolocation of people with Alzheimer's", International Journal of Electrical and Computer Engineering (IJECE), 2024
Publication 1%
- 4 Charlotte Schneider, Marcia Nißen, Tobias Kowatsch, Rasita Vinay. "Impact of digital assistive technologies on the quality of life for people with dementia: A scoping review", Cold Spring Harbor Laboratory, 2023 1%

5 Alexandra L. Clark, Abbey M. Hamlin, Nazareth Ortega, Jordana Breton. "Social and structural determinants of cognitive and brain aging outcomes in racially/ethnically minoritized older adults", Elsevier BV, 2024 1%

Publication

6 Anita Ramachandran, Adarsh Ramesh, Piyush Pahwa, A. Prahalad Atreyaa, Shivam Murari, K. R. Anupama. "Performance Analysis of Machine Learning Algorithms for Fall Detection", 2019 IEEE International Conference on E-health Networking, Application & Services (HealthCom), 2019 1%

Publication

7 Dhruv Parikh, Manan Shah. "A comprehensive study on epigenetic biomarkers in early detection and prognosis of Alzheimer's disease", Biomedical Analysis, 2024 1%

Publication

8 Fang-Yi Lin, Po-Ting Lee, Yuan-Hao Ho, Pi-Shan Sung, Peng-Ting Chen, Chih-Lung Lin. "Fall Prediction Based on Head-Mounted IMU Sensor System", 2022 IEEE 11th Global Conference on Consumer Electronics (GCCE), 2022 1%

Publication

9 Preeti Sadanand Topannavar, Dinkar M. Yadav. "An effective feature selection using improved marine predators algorithm for Alzheimer's disease classification", International Journal of Electrical and Computer Engineering (IJECE), 2023 1%

Publication

10 Usman Anwar, Tughrul Arslan, Amir Hussain, Peter Lomax. "Next Generation Cognition-Aware Hearing Aid Devices With Microwave Sensors: Opportunities and Challenges", IEEE Access, 2022

1%

Publication

11 Zulhipni Reno Saputra Elsi, Deris Stiawan, Bhakti Yudho Suprpto, M. Agus Syamsul Arifin, Mohd. Yazid Idris, Rahmat Budiarto. "Revolutionizing internet of things intrusion detection using machine learning with unidirectional, bidirectional, and packet features", IAES International Journal of Artificial Intelligence (IJ-AI), 2025

1%

Publication

12 Jerónimo, Carlos Miguel Correia Hernandez. "Business Models Reinvention: From Staffing to Management Consulting Case", ISCTE - Instituto Universitario de Lisboa (Portugal), 2024

1%

Publication

13 Philipp Mayer, Michele Magno, Luca Benini. "Energy-Positive Activity Recognition - From Kinetic Energy Harvesting to Smart Self-Sustainable Wearable Devices", IEEE Transactions on Biomedical Circuits and Systems, 2021

1%

Publication

14 Amjad Bashayreh, Nida'a Alsalman, Ahmad Alzu'bi. "Alive+: A Private Cloud Messaging System for Android Devices", 2021 12th International Conference on Information and Communication Systems (ICICS), 2021

1%

Publication

Lecture Notes in Computer Science, 2010.

15

Publication

1 %

16

Madhav Acharya, Ravinesh C Deo, Prabal Datta Barua, Aruna Devi, Xiaohui Tao. "EEGConvNeXt: A Novel Convolutional Neural Network Model for Automated Detection of Alzheimer's Disease and Frontotemporal Dementia Using EEG Signals", Computer Methods and Programs in Biomedicine, 2025

Publication

1 %

17

Xiaomin Li, Bingfa Hou, Rihong Zhang, Yongxin Liu. "A Review of RGB Image-Based Internet of Things in Smart Agriculture", IEEE Sensors Journal, 2023

Publication

1 %

18

Paul F. Hill, Arne D. Ekstrom. "A cognitive-motor framework for spatial navigation in aging and early-stage Alzheimer's disease", Cortex, 2025

Publication

1 %

19

Saswat Pandey, Ayush Goyal, David Hicks. "A Blood Pressure and Heartbeat Anomaly Detection and Notification Mobile Application System (BPHADNS)", 2018 International Conference on Computational Science and Computational Intelligence (CSCI), 2018

Publication

1 %

Exclude quotes Off

Exclude matches < 1%

Exclude bibliography Off